

NATIONAL INSTITUTE FOR FUSION SCIENCE

A Steady State Tokamak Operation by Use of Magnetic Monopoles

K. Narihara

(Received – Dec. 4, 1991)

NIFS-126

Dec. 1991

RESEARCH REPORT NIFS Series

This report was prepared as a preprint of work performed as a collaboration research of the National Institute for Fusion Science (NIFS) of Japan. This document is intended for information only and for future publication in a journal after some rearrangements of its contents.

Inquiries about copyright and reproduction should be addressed to the Research Information Center, National Institute for Fusion Science, Nagoya 464-01, Japan.

**A STEADY STATE TOKAMAK OPERATION
BY USE OF MAGNETIC MONOPOLES**

K. Narihara

National Institute for Fusion Science, Nagoya 464-01 Japan

ABSTRACT

A steady state tokamak operation based on a magnetic monopole circuit is considered. Circulation of a chain of iron cubes which trap magnetic monopoles generates the needed loop voltage. The monopole circuit is enclosed by a series of solenoid coils in which the magnetic field is feedback controlled so that the force on the circuit balance against the mechanical friction. The driving power is supplied through the current sources of poloidal, ohmic and solenoid coils. The current drive efficiency is same as that of the ohmic current drive.

KEY WORDS

Magnetic monopole, current drive, steady state tokamak

1. INTRODUCTION

Efficient steady state current drive is one of the key issues in realizing an economically competitive tokamak fusion reactor (Ehst *et al.*, 1985(a); Ehst *et al.*, 1985(b)). In line with this recognition, intensive efforts have been continued to improve the efficiencies of the lower hybrid wave current drive (LHCD) (Abe *et al.*, 1987), the electron cyclotron wave current drive (ECCD) (Tanaka *et al.*, 1988), and the neutral beam injection current drive (NBCD) (Simonen *et al.*, 1986), the principles of which have already been demonstrated. Also efforts have been pursued to find evidences of the current drives by the fast magnetosonic waves (Ando *et al.*, 1986) and by the helicity injection (Ono *et al.*, 1987). Among the recent results, the most impressive is the experimental demonstration that appreciable amount of toroidal current is carried by the bootstrap current in the high poloidal beta condition (Hawrylux *et al.*, 1987). Many other schemes of current drives have been conceived and reviewed, together with the above, by Fisch (1987). Notwithstanding all these recent significant progress, the present state of the research seems to be that, no current drive scheme has yet been found which can be straightforwardly adopted to a steady state tokamak fusion reactor: each scheme has problems such as the low current drive efficiency; the large gap between the plasma parameter region suitable for efficient current drive and that yielding high fusion reaction; and the incompatibility between the spatial profile of the driven current and that suitable for stability and good plasma confinement. Thus, finding new methods of driving toroidal current is still an important issue in this field.

An easily conceivable but perhaps not published scheme of toroidal current drive is the use of magnetic monopoles (monopoles in brief

henceforth), particles which carry magnetic charge. It is Dirac (1931) who first put forward a persuasive argument for the existence of monopoles. He verified that, if monopoles exist, then the electric charge should be integer multiples of a fundamental unit as is actually observed in nature. A more persuasive argument was independently given by Polyakov (1974) and 't Hooft (1974), who showed that any grand unification theory (GUT) of the strong and electroweak gauge interactions necessarily leads to the existence of the monopoles. Furthermore, based on the theory, the properties of monopoles such as the magnetic charge, the core size, and the mass are predictable. Because of the fundamental importance, many efforts have been made without success to search for monopoles in cosmic rays (Cabrera *et al.*, 1983) , the collision regions of high energy accelerators (Purcell *et al.*, 1963), ferromagnetic materials (Goto *et al.*, 1963), and extraterrestrial materials (Ross *et al.*, 1973). Without confident evidence for magnetic monopoles, it might be absurd to consider their application to technologies. However, considering the great impact it would have on the fusion research if appreciate amount of monopoles were discovered, this may not be necessarily the case. With a hope that substantial amount of magnetic monopoles could be gathered from some exotic materials, this paper describes a scheme of maintaining the electric toroidal current of a tokamak plasma by use of magnetic monopoles.

2. PRINCIPLE OF MAGNETIC MONOPOLE CURRENT DRIVE

The monopole which we treat here is taken to be the Dirac monopole which carries the fundamental magnetic charge

$$g_0 = h/e = 4.14 \times 10^{-15} \quad \text{Weber} \quad (1)$$

and its mass is treated as a free parameter. If a magnetic charge of g is made to go endlessly along a circuit which interlinks the toroidal plasma as is depicted in Fig.1, the magnetic field emanating from the charge is deformed, stretched, reconnected if possible, and wound around the plasma infinitely thereby generating the loop voltage equal to $g \cdot f$ with f being the circulation frequency. This is the intuitive explanation of the monopole current drive. A more rigorous description is given based on the generalized electromagnetic theory which permits the existence of monopoles (Jackson, 1975). If there exist magnetic charge and current densities, (ρ_m, \vec{j}_m) , in addition to the electric one (ρ_e, \vec{j}_e) , then the usual Maxwell field equations are generalized as

$$\nabla \times \vec{H} = \frac{\partial \vec{D}}{\partial t} + \vec{j}_e, \quad (2)$$

$$\nabla \times \vec{E} = -\frac{\partial \vec{B}}{\partial t} - \vec{j}_m, \quad (3)$$

$$\nabla \cdot \vec{D} = \rho_e, \quad (4)$$

$$\nabla \cdot \vec{B} = \rho_m, \quad (5)$$

where the notation for the fields are conventional. On the other hand, the electromagnetic force on a monopole with charge g and velocity \vec{v}_m is given by

$$\vec{F}_m = g(\vec{H} - \vec{v}_m \times \vec{D}), \quad (6)$$

which should be compared with the Lorentz force exerted on a particle with an electric charge q and velocity \vec{v}_e

$$\vec{F}_e = q(\vec{E} + \vec{v}_e \times \vec{B}). \quad (7)$$

It should be noted above that the electric and magnetic fields appear in a

symmetric manner. This symmetry suggests that an axial magnetic current generates the toroidal electric field just as the axial electric current generates the toroidal magnetic field. To see this we consider a situation in which a magnetic current is flowing through the central hole of a toroidal plasma. Integrating Eq.(3) over the area S bounded by the circle which runs along the center of the plasma and using the Stokes's theorem, we obtain

$$\oint_c \vec{E} \cdot d\vec{\ell} = -\frac{\partial \Psi}{\partial t} - I_g, \quad (8)$$

where

$$\Psi = \iint \vec{B} \cdot d\vec{S} \quad (9)$$

is the magnetic flux linking the ring and

$$I_g = \iint \vec{j}_m \cdot d\vec{S} \quad (10)$$

is the magnetic current passing through the hole of the ring. Eq.(8) shows that the magnetic current I_g generates the loop voltage $V_{\text{loop}} = -I_g$, which in turn drives the toroidal electric current in the plasma given by

$$I_t = V_{\text{loop}} / R_p = -I_g / R_p, \quad (11)$$

where R_p is the loop electric resistance of the plasma. This is the plasma current driven by the magnetic monopole current.

3. A Tokamak Equipped with a Monopole Circuit

As stated in the previous section, a steady state toroidal current is maintained by circulating monopoles along a closed circuit which interlinks the tokamak plasma. Several methods may be imagined of circulating monopoles. One is to use a cyclic monopole accelerator interlinking the toroidal plasma, in which free monopoles are guided and focused by electric field and accelerated by magnetic field. This method enables the monopoles, if they are not too heavy, to run at such a very high speed that a sufficient magnetic current is obtained with a small number of monopoles, but there is a possibility that very expensive monopoles are gradually lost due to an incomplete confinement. Another way is to circulate a chain of iron blocks in which monopoles are trapped. We like to imagine to equip a next generation tokamak like FER (Fujisawa, et al., 1986) with a monopole circuit of the chain type. A possible configuration is shown in Fig. 2(a). In what follows we examine some of the problems concerning physics and engineering and consider the overall features of this system.

3-1. Necessary magnetic current

In designing a monopole circuit for toroidal current drive, the relevant plasma parameters are the loop voltage V_{loop} and the toroidal plasma current J_p . In order to reduce the burden on the monopole circuit, we suppose that plasma formation and current ramp-up in the start-up phase is performed by the induction of the ohmic heating (OH) coils and the monopole circuit running continuously holds the established toroidal current. After heating and fueling to ignition, the plasma current of $J_p = 10$ MA is supposed to be maintained by the loop voltage of $V_{loop} = 0.1$ V. Then from Eq.(8), the required monopole current is 0.1 V. Considering the the size

of the tokamak, we suppose that the chain of iron cubes, each containing monopoles, of 100 m in circumference circulates at the speed of 0.1 circulation/s. Then the necessary magnetic charge is $0.1 \text{ V} / 0.1 \text{ s}^{-1} = 1$ Weber, and the required number of magnetic monopoles is

$$N_g = Q_m / g_0 = 2.4 \times 10^{14}, \quad (12)$$

which is distributed along the circumference of 100 m. It is noted that a relatively small number of monopoles are sufficient for steady state operation of the next generation tokamak.

3-2. Trapping monopoles on the iron cubes

Just as an electric charge is trapped on the surface of a conductor or dielectric material by the image force, a monopole is trapped on the surface of a ferromagnetic material (iron) by the induced magnetization, but the situation is more complex because of the saturation effect.

Goto *et al* (1963) calculated the trapping field $H(z)$ on a monopole placed at the distance z from the infinite plane interface of a model ferromagnetic material:

$$H_z(z) = \begin{cases} -a(z)g_0 / 32\pi\mu_0 z^2 & \text{if } z \geq a(z)^{0.5}R_s \\ -M_s \left[\frac{1}{2} \ln \left(\frac{a(z)^{0.5}R_s}{z} \right) + \frac{z^2}{8a(z)R_s^2} \right] & \text{otherwise,} \end{cases} \quad (13)$$

where M_s is the saturation field intensity, $a(z)g_0$ is the magnetic charge of the image pole, and R_s the saturation radius defined by

$$R_s = (g_0 / 4\pi\mu_0 M_s)^{0.5}. \quad (14)$$

The function $a(z)$, ranging from 1 to 2, should be chosen so that it gives correctly the induced field at all positions. Taking a model function for $a(z)$ and choosing a lower cutoff distance $z_{\min} = 0.1 \text{ nm}$ to avoid the logarithmic divergence for $z \rightarrow 0$, they obtained the maximum trapping field H_{\max} of 5.3 T for iron ($\mu_0 M_s = 2.2 \text{ T}$). In general H_{\max} is expressed as

$$H_{\max} = KM_s, \quad (15)$$

where K is a constant ranging from 1 to 3 which is weakly dependent on the model adopted. The extraction energy, which is often more convenient than the trapping force, is given by the path integration of the force

$$\int_{z_{\min}}^{\infty} g_0 H(z) dz, \quad (16)$$

which is about 740 eV for the model they used and large enough to confine a monopole against the thermal motion at the room temperature.

The above is about the trapping of a single monopole. When many monopoles are trapped, the mutual repulsion of the monopoles will weaken the trapping force. By analogy of the electrostatics, which is valid if no saturation occurs, the layer of the monopoles with the surface density σ_s generates a detrapping field $H_s = \sigma_s g_0 / \mu_0$, which is the sum of the fields due to the surface charge itself $\sigma_s g_0 / 2\mu_0$ and the induced field $\sigma_s g_0 / 2\mu_0$. If saturation occurs, the induced field and then the resultant field is reduced somewhat. In any case, the resultant field intensity is around $H_s \sim \sigma_s g_0 / \mu_0$. The necessary condition that $H_{\max} \gg H_s$ leads to a constraint on the surface density σ_s :

$$\sigma_s \ll K / 4\pi R_s^2 = 1.3 \times 10^{15} \text{ m}^{-2} \quad \text{for iron.} \quad (17)$$

Against the force thus obtained, there are two dominant detrapping forces in addition to the thermal force already mentioned. The first is due to the

external magnetic field directing to the normal of the ferromagnetic material H_{ext} . Obviously for effective monopole trapping it is necessary that

$$\mu_0 H_{ext} < \mu_0 H_{max} = 5.3 \text{ T} \quad \text{for iron.} \quad (18)$$

Another detrapping force is gravitation $F=GM_m$, where M_m is the mass of the monopole and G is the gravitational acceleration at the position where the iron cubes are placed. The trapping condition, $g_0 H_{max} \gg M_m G$, leads to a constraint on the range of the monopole mass times the gravitational constant:

$$M_m G \ll 1.7 \times 10^{-8} \text{ Kg N.} \quad (19)$$

For Earth's gravitation, $G= 9.8 \text{ m}^2\text{s}^{-1}$, the detrapping mass is $1.8 \times 10^{-9} \text{ kg} \sim 1.0 \times 10^{18} \text{ GeV}/c^2$, which is larger than the mass expected by SU(5) GUT theory, $M_{SU(5)} \sim 10^{16} \text{ GeV}/c^2$. Since the trapping occurs only in the normal direction of the ferromagnetic material, an external force which has the tangential component drives monopoles along the surface. Therefore each iron cube should be isolated from others by non-ferromagnetic material, for example, stainless steel SUS304.

3.3 Drivers of the monopole circuit and current drive efficiency

Referring to Fig. 2(a), we first consider to drive the monopole circuit which interlinks the the poloidal and OH coils and the plasma by a conventional electric motor with some mechanical transmissions. For ease of analysis we suppose that the monopoles are uniformly distributed along the circuit with the line density of $g_l = 0.01 \text{ Weber/m}$. In a steady state, the driving force should be equal to the path integration of the force density $g_l \vec{H}$ along the circuit:

$$F_{\text{DRV}} = \oint g_{\ell} \vec{H} \cdot d\vec{\ell} + \Gamma v_{\text{cir}} = g_{\ell} \left(\sum_{i=1}^m n_i J_i + J_p \right) + \Gamma v_{\text{cir}}, \quad (20)$$

where J_i ($i=1, m$; m being the number of coils) is the electric current passing through the i -th coil with n_i windings, J_p is the plasma current. Here the inevitable frictional force, presented by Γv_{cir} with Γ being the coefficient of dynamical friction and v_{cir} the circulation speed, is added to the magnetic force. The power necessary to drive the motor is

$$P_{\text{DRV}} = F_{\text{DRV}} v_{\text{cir}} = \left(\sum_{i=1}^m n_i J_i + J_p \right) V_{\text{loop}} + \Gamma v_{\text{cir}}^2, \quad (21)$$

where

$$V_{\text{loop}} = g_{\ell} v_{\text{cir}} \quad (22)$$

is the loop voltage induced by the monopole circulation. The magnitude of $\left(\sum_{i=1}^m n_i J_i + J_p \right)$, of course, depends on the poloidal and OH coils configuration,

but, in general, $\left| \sum_{i=1}^m n_i J_i + J_p \right| < J_p$ because the directions of the most coil currents are opposite to that of the plasma current. Then

$$P_{\text{DRV}} < J_p V_{\text{loop}} + \Gamma v_{\text{cir}}^2, \quad (23)$$

which means that the power to drive the motor is less than the plasma ohmic loss plus the circuit frictional loss. This apparent paradox is solved if we correctly take into account the power necessary to drive poloidal and OH coils. In the steady state, the circuit equation for the i -th coil current J_i ($i=1, m$) is given by

$$R_i J_i = V_i + n_i V_{\text{loop}}, \quad (24)$$

where R_i is the resistance of the i -th circuit and V_i is the external electromotive force applied to the i -th circuit. Similarly for plasma current,

$$R_p J_p = V_{loop} \quad (25)$$

where R_p is the loop resistance of the toroidal plasma. The total power necessary to drive the coil currents and the motor is

$$P = \sum_{i=1}^m J_i V_j + F_{DRV} v_{cir} = \sum_{i=1}^m R_i J_i^2 + \Gamma v_{cir}^2 + V_{loop} J_p. \quad (26)$$

The first term on the right hand side is the ohmic loss in the coils and presumably becomes negligibly small if superconducting coils are used. The second term is the mechanical frictional loss in the monopole circuit and may be small enough. If these terms are thus dropped,

$$P = V_{loop} J_p = R_p J_p^2, \quad (27)$$

which is just the power necessary to compensate the ohmic loss in the plasma and therefore the current drive efficiency is the same as that of the ohmic current drive. This is quite natural since the monopole current drive is essentially inductive current drive as is apparent from Eq.(8). Another power loss, not accounted above, arises from the hysteresis loss of the ferromagnetic material due to the variation of the external field seen by iron cubes and the drift of monopoles along the surface as it circulates around the plasma, but this loss will be reduced to a tolerable level by using a same soft iron as is used for transformers.

It is noted above that, of the total necessary power, $J_p V_{loop}$, to maintain the toroidal current, the appreciable amount, $-\sum_{i=1}^m n_i J_i V_{loop}$, is supplied through the poloidal and OH coil systems. This fact immediately suggests us that we may replace the driving motor by an appropriate coil system. The monopole circuit is housed in a series of compensation solenoid coils (Fig.2(b)) which generates uniform magnetic field along the circuit the intensity of which is just to drive the circuit against the mechanical friction;

$F_{DRV}=0$. In fact, it is this scheme that guarantees the effective trapping of the monopoles in the otherwise very strong magnetic fields. This scheme is also very favorable for making the monopole circuit very compact since the tension on the circuit is very small. However, the operation at the start up should be carefully pursued; otherwise, the monopoles may be detrapped and the joint of the circuit be broken by the strong magnetic field due to incorrect compensation. With pickup coils and a computer aided current control system, it may be quite easy to maintain the magnetic field along the circuit at the appropriate intensity.

3.4. Consideration of the overall system

Now that we have examined some of the key issues and obtained several constrains, we consider an overall system consistent with the above constrains. It is assumed that the monopole circuit of 100 m in circumference consists of 2000 iron cubes with a base of 0.02 m long, each containing 1.2×10^{11} monopoles. The surface density of the monopole is then $3.0 \times 10^{14} \text{ m}^{-2}$, which is smaller than the critical surface density, Eq(17), at which monopoles will be detrapped due to mutual repulsion. Here we assume that monopoles are localized in one surface of the cube under the external force fields. As shown in Fig.2(c), each iron cube is buried in a non-magnetifc stainless steal (SUS 304) block with joints at both ends in order to magnetically isolate each iron cube from others. The cross section of the joint is $2.25 \times 10^{-4} \text{ m}^2$, which will safely withstand the tension of up to $2 \times 10^4 \text{ N}$. If we neglect the mass of the monopoles, the total mass of the chain amounts to 720 kg and the corresponding kinetic energy is 36 kJ.

For monopoles not to be detrapped, the magnetic field along the monopole circuit should be less than the trapping field of 5.3 T. The monopole circuit is housed inside a series of compensation solenoid coils in which the magnetic field is feedback controlled at the level just to drive the circuit against the mechanical frictional force. If the frictional force is assumed to be 1000 N, which gives the e-folding time of 7.2 s for the freely decaying circulation, the necessary magnetic field is 12.5×10^{-4} T, which is much smaller than the detrapping field of 5.3 T. The 0.1 m diameter bore of the compensation coils is large enough to house the chain of SUS 304 block and wheels which support the chain (Fig. 2(b)). The monopole circuit draws an straight lines in the central and outer parts and semi-circles in the upper and lower parts. The maximum curvature of the circuit is around 10 m and the centrifugal acceleration is then $G_{cen} \sim 10 \text{ ms}^{-2}$, which is comparable in magnitude to the earth's gravitation and then will not introduce the problem concerning the detapping of monopoles from the iron cubes.

The monopole circuit generates magnetic field as well as toroidal electric field. This magnetic field is of great concern because it may break axisymmetry of the tokamak, which in turn, may deteriorate the confinement properties of the tokamak. The central part of the monopole circuit generates an axial symmetric radial magnetic field of $B_R \sim 3.2 \times 10^{-4}$ T at $R=5$ m, which will deform the magnetic surfaces but will not induce to form the magnetic island because it preserves the axisymmetry. Contrary to this, the other part of the circuit generates an asymmetric magnetic field, magnitude of which is roughly estimated to be of the order of 10^{-4} T at the edge of the plasma, which seems within a tolerable level in comparing with the toroidal ripple due to the finite number of toroidal coils.

Since the monopole current is essentially an inductive drive as is evident from Eq.(8), the efficiency of the current drive and the spatial profile of the driven current are same as those of OH current drive.

4. DISCUSSION AND CONCLUSION

Among many questions not yet addressed, the most critical one is the sources of monopoles. The long history of intense searches for monopoles without a confident evidence in all conceivable sources around us indicates that the possibility of finding large amount of monopoles is extremely small. Upper bound of $F_m = 1 \times 10^{-19} \text{ m}^{-2} \text{ sr}^{-1} \text{ sec}^{-1}$ on the monopole flux of cosmic origin was estimated on the basis of the survival argument of the galactic magnetic field (Parker, 1970). If the mass of monopole is as heavy as that predicted by GUT, there will be no possibility of generating monopoles by the foreseen particle accelerators. Therefore the possible sources should be explored in the not experienced places, such as the interior of the earth, sun and the collapsed star. Exotic matter such a mini-black hole, if present, may be a possible candidate of the monopole source because it is a relic of the early universe, at which time plenty of monopoles are assumed to be present (Hiscock, 1983). Although exploring such exotic places is far beyond the present day human ability, no one can deny the far future possibility of collecting plenty of monopoles in such places.

Since monopoles generate and interact with electromagnetic fields, on which the present day technology heavily depends, many other applications may be considered. One of them is the monopole motor, a variant of which was already used here for driving the monopole circuit .

In conclusion, construction of a steady state next generation tokamak based on the monopole current drive system seems to be feasible from the

view points of physics and engineering. The problem is where we can find plenty of monopoles.

REFERENCES

- Abe, T. *et al.* (1987) in *Plasma Physics and Controlled Nuclear Fusion Research 1986* (Proc. 11 th Int. Conf. Kyoto, 1986), Vol. 1, IAEA, Vienna (1987), 563.
- Ando R., Kako E., Ogawa Y. (1986) *Nucl. Fusion* **26**, 1619.
- Cabrera B., Taber N., Gardner R. and Bourg J. (1983) *Phys. Rev. Lett.* **51**, 1933.
- Dirac, P. M. A. (1931) *Proc. Roy. Soc. (London)* **A133**, 60.
- Ehst, D. A., Cha Y., Hassanein A. M., Majumdar S., Misra B. and Stevens C. (1985 a) *Nucl.Engrg.Des./Fusion* **2**, 305.
- Ehst, D. A., Brooks J. N., Evans Jr. K. and Kim S. (1985b) *Nucl.Engrg.Des./Fusion* **2**, 319.
- Fisch N.J. (1987) *Rev. Mod. Phys.* **59**,175.
- Fujisawa N. and FER Plasma Design Group (1986) in *Tokamak Start-up*, ed. H. Knoepfel (Plenum Press, New York and London, 1986), p. 111.
- Goto E., Kolm H. H. and Ford K. W. (1963) *Phys. Rev.* **132**, 387.
- Hawryluk R.J., Arunasalum V., Bell M. G. *et al.* (1987) in *Plasma Physics and Controlled Nuclear Fusion Research 1986* (Proc. 11 th Int. Conf. Kyoto, 1986), Vol. 1, IAEA, Vienna (1987), p. 51.
- Hiscock W. A. (1983) *Phys. Rev. Lett.* **50**, 1734.
- Jackson J. D. (1975) *Classical Electrodynamics* (Wiley, 1975), 2nd ed., p.251.
- Ono M., Greene G. J., Darrow D., Forest C., Park H. and Stix T.H. (1987) *Phys. Rev. Lett.* **59**, 2165.
- Parker, E. N. (1970) *Astrophys. J.* **160**, 383.
- Polyakov, A. (1974) *JETP Letters* **20**, 194.

- Purcell E. M., Cokkins G. B., Fujii T., Hornbostel J. and Turkot F. (1963) *Phys. Rev.* **129**, 2326.
- Ross R. R., Eberhard P. H. and Alvarez L.W. (1973) *Phys. Rev.* **D8**, 698.
- Simonen T.C., Matsuoka M., Bhadra D. A. *et al.* (1986) *Phys. Rev. Lett.* **61**, 1720.
- Tanaka H., Ando A., Ogura K., Ide S. *et al.* (1988) *Phys. Rev. Lett.* **60**, 1033.
- t'Hooft, G. (1974) *Nucl. Phys.* **B79**, 276.

FIGURE CAPTIONS

- Fig.1. A field line behavior as a magnetic charge circulates along a circuit which interlink a toroidal plasma. The magnetic charge winds field lines along the toroidal plasma infinitely thereby generating a loop voltage equal to the circulation frequency times the magnetic charge.
- Fig.2. (a) A next generation tokamak equipped with a magnetic monopole circuit.
- (b) A section of the magnetic monopole circuit. A chain of the stainless steel blocks is housed in a solenoid coils in which the magnetic field intensity is controlled so that the magnetic force on the chain balance with the frictional force.
- (c) One piece of the chain. Magnetic monopoles are trapped on the surfaces of the iron cube which is buried inside the nonmagnetic stainless steel (SUS 304) blocks with joints at both sides.

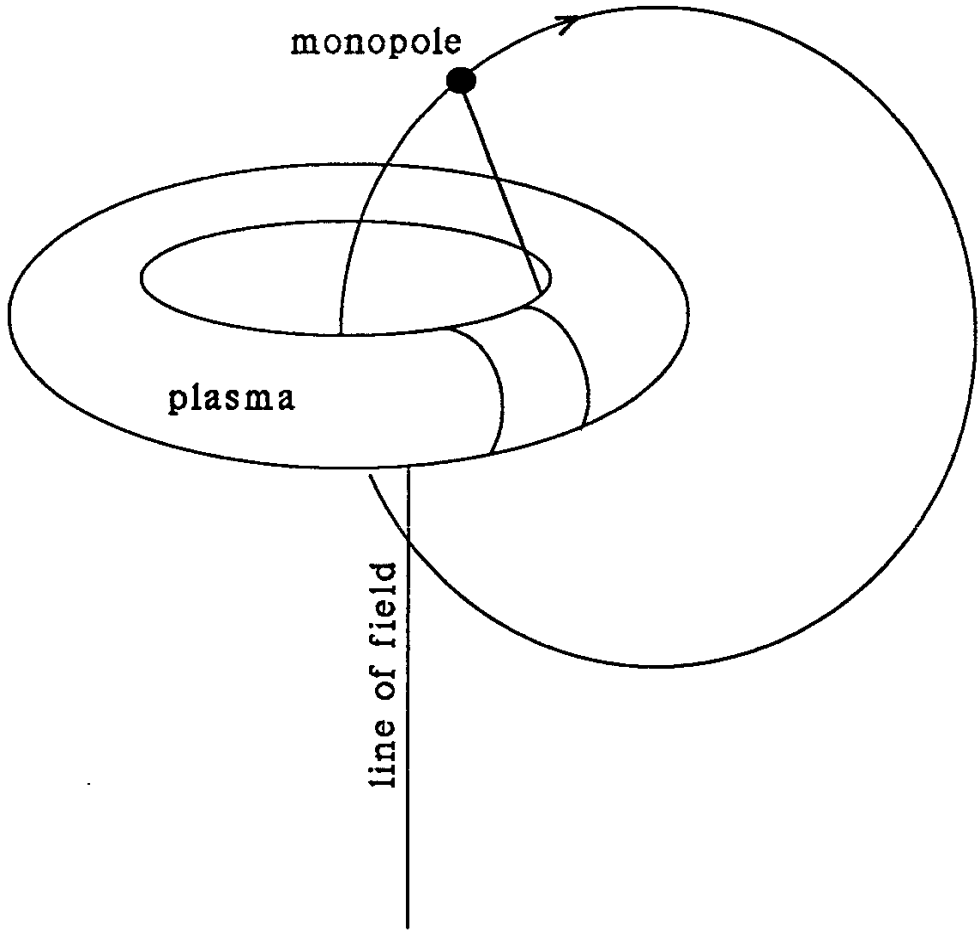

Fig.1. A field line behavior as a magnetic charge circulates along a circuit which interlinks a toroidal plasma. The magnetic charge winds field lines along the toroidal plasma infinitely thereby generating a loop voltage equal to the circulation frequency times the magnetic charge.

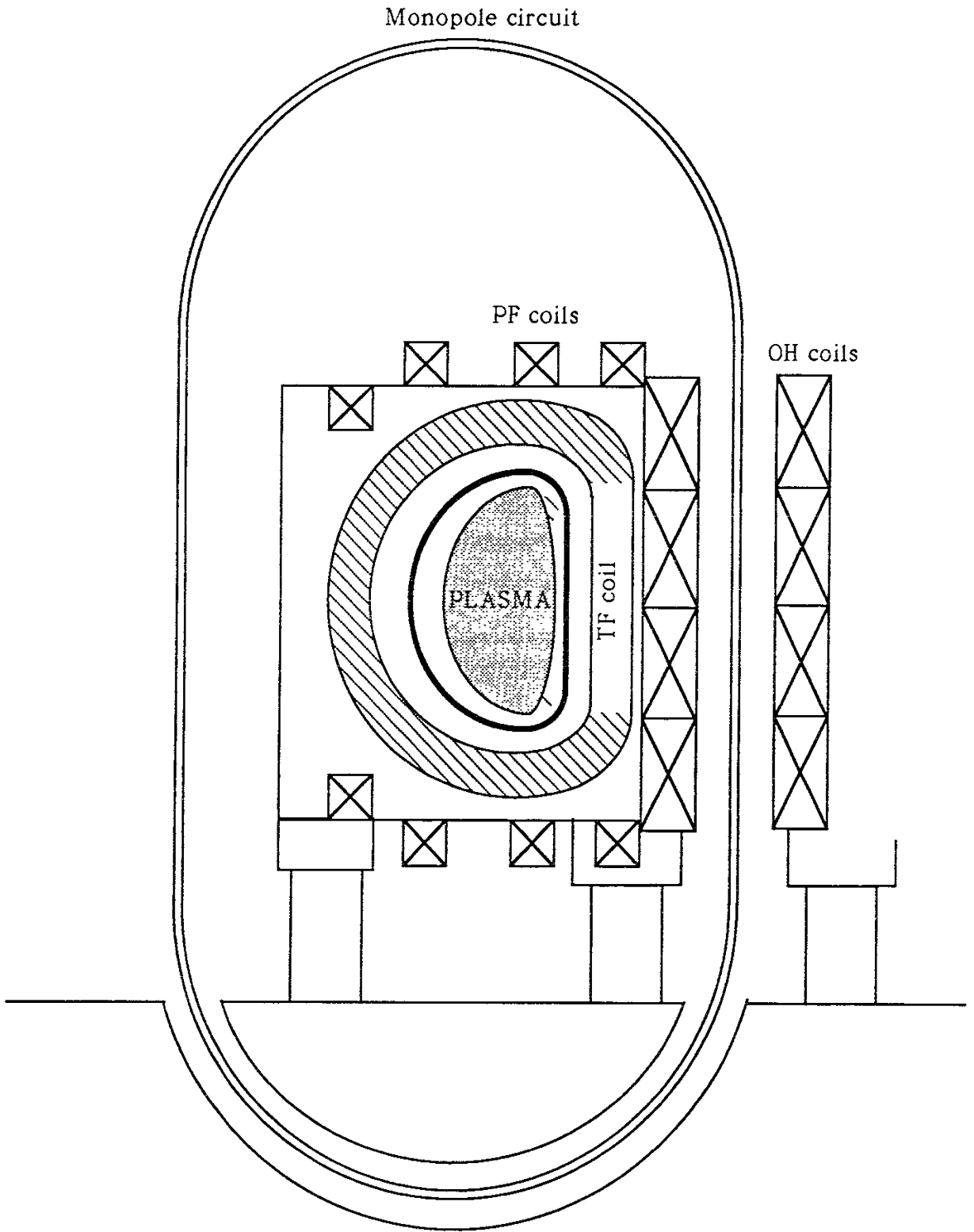

Fig.2. (a) A next generation tokamak equipped with a magnetic monopole circuit.

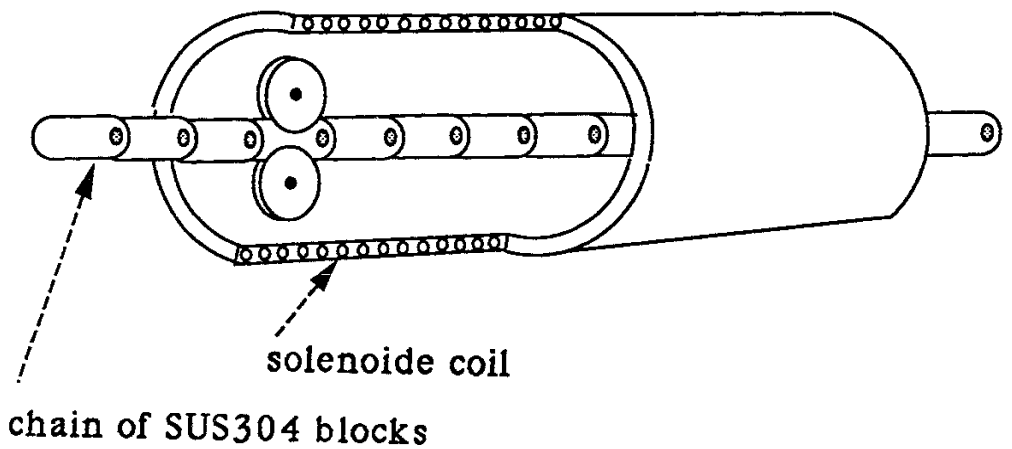

Fig. 2(b) A section of the magnetic monopole circuit. A chain of the stainless steel blocks is housed in a solenoid coils in which the magnetic field intensity is controlled so that the magnetic force on the chain balance with the frictinal force.

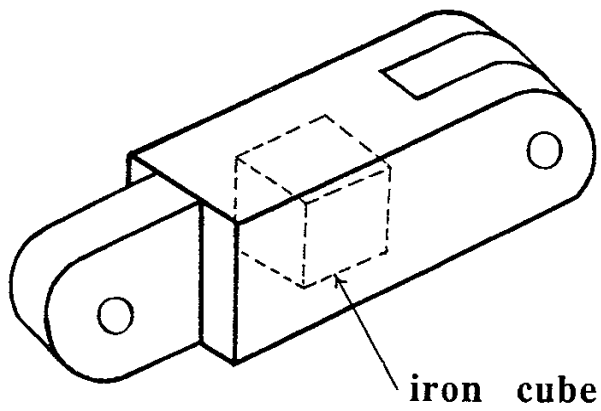

Fig. 2(c) One piece of the chain. Magnetic monopoles are trapped on the surfaces of the iron cube which is buried inside a nonmagnetic stainless steel (SUS 304) block with joints at both sides.

Recent Issues of NIFS Series

- NIFS-67 K.Sato, and F.Miyawaki, *Effects of a Nonuniform Open Magnetic Field on the Plasma Presheath*; Jan.1991
- NIFS-68 K.Itoh and S.-I.Itoh, *On Relation between Local Transport Coefficient and Global Confinement Scaling Law*; Jan. 1991
- NIFS-69 T.Kato, K.Masai, T.Fujimoto, F.Koike, E.Källne, E.S.Marmor and J.E.Rice, *He-like Spectra Through Charge Exchange Processes in Tokamak Plasmas*; Jan.1991
- NIFS-70 K. Ida, H. Yamada, H. Iguchi, K. Itoh and CHS Group, *Observation of Parallel Viscosity in the CHS Heliotron/Torsatron* ; Jan.1991
- NIFS-71 H. Kaneko, *Spectral Analysis of the Heliotron Field with the Toroidal Harmonic Function in a Study of the Structure of Built-in Divertor* ; Jan. 1991
- NIFS-72 S. -I. Itoh, H. Sanuki and K. Itoh, *Effect of Electric Field Inhomogeneities on Drift Wave Instabilities and Anomalous Transport* ; Jan. 1991
- NIFS-73 Y.Nomura, Yoshi.H.Ichikawa and W.Horton, *Stabilities of Regular Motion in the Relativistic Standard Map*; Feb. 1991
- NIFS-74 T.Yamagishi, *Electrostatic Drift Mode in Toroidal Plasma with Minority Energetic Particles*, Feb. 1991
- NIFS-75 T.Yamagishi, *Effect of Energetic Particle Distribution on Bounce Resonance Excitation of the Ideal Ballooning Mode*, Feb. 1991
- NIFS-76 T.Hayashi, A.Tadei, N.Ohyabu and T.Sato, *Suppression of Magnetic Surface Breeding by Simple Extra Coils in Finite Beta Equilibrium of Helical System*; Feb. 1991
- NIFS-77 N. Ohyabu, *High Temperature Divertor Plasma Operation*; Feb. 1991
- NIFS-78 K.Kusano, T. Tamano and T. Sato, *Simulation Study of Toroidal Phase-Locking Mechanism in Reversed-Field Pinch Plasma*; Feb. 1991
- NIFS-79 K. Nagasaki, K. Itoh and S. -I. Itoh, *Model of Divertor Biasing and Control of Scrape-off Layer and Divertor Plasmas*; Feb. 1991
- NIFS-80 K. Nagasaki and K. Itoh, *Decay Process of a Magnetic Island by Forced Reconnection*; Mar. 1991
- NIFS-81 K. Takahata, N. Yanagi, T. Mito, J. Yamamoto, O.Motojima and LHDDesign Group, K. Nakamoto, S. Mizukami, K. Kitamura, Y. Wachi, H. Shinohara, K. Yamamoto, M. Shibui, T. Uchida and K. Nakayama, *Design and Fabrication of Forced-Flow Coils as R&D Program for Large Helical Device*; Mar. 1991

- NIFS-82 T. Aoki and T. Yabe, *Multi-dimensional Cubic Interpolation for ICF Hydrodynamics Simulation*; Apr. 1991
- NIFS-83 K. Ida, S.-I. Itoh, K. Itoh, S. Hidekuma, Y. Miura, H. Kawashima, M. Mori, T. Matsuda, N. Suzuki, H. Tamai, T. Yamauchi and JFT-2M Group, *Density Peaking in the JFT-2M Tokamak Plasma with Counter Neutral Beam Injection* ; May 1991
- NIFS-84 A. Iiyoshi, *Development of the Stellarator/Heliotron Research*; May 1991
- NIFS-85 Y. Okabe, M. Sasao, H. Yamaoka, M. Wada and J. Fujita, *Dependence of Au⁻ Production upon the Target Work Function in a Plasma-Sputter-Type Negative Ion Source*; May 1991
- NIFS-86 N. Nakajima and M. Okamoto, *Geometrical Effects of the Magnetic Field on the Neoclassical Flow, Current and Rotation in General Toroidal Systems*; May 1991
- NIFS-87 S. -I. Itoh, K. Itoh, A. Fukuyama, Y. Miura and JFT-2M Group, *ELMy-H mode as Limit Cycle and Chaotic Oscillations in Tokamak Plasmas*; May 1991
- NIFS-88 N. Matsunami and K. Itoh, *High Resolution Spectroscopy of H⁺ Energy Loss in Thin Carbon Film*; May 1991
- NIFS-89 H. Sugama, N. Nakajima and M. Wakatani, *Nonlinear Behavior of Multiple-Helicity Resistive Interchange Modes near Marginally Stable States*; May 1991
- NIFS-90 H. Hojo and T. Hatori, *Radial Transport Induced by Rotating RF Fields and Breakdown of Intrinsic Ambipolarity in a Magnetic Mirror*; May 1991
- NIFS-91 M. Tanaka, S. Murakami, H. Takamaru and T. Sato, *Macroscale Implicit, Electromagnetic Particle Simulation of Inhomogeneous and Magnetized Plasmas in Multi-Dimensions*; May 1991
- NIFS-92 S. - I. Itoh, *H-mode Physics, -Experimental Observations and Model Theories-, Lecture Notes, Spring College on Plasma Physics, May 27 - June 21 1991 at International Centre for Theoretical Physics (IAEA UNESCO) Trieste, Italy* ; Jun. 1991
- NIFS-93 Y. Miura, K. Itoh, S. - I. Itoh, T. Takizuka, H. Tamai, T. Matsuda, N. Suzuki, M. Mori, H. Maeda and O. Kardaun, *Geometric Dependence of the Scaling Law on the Energy Confinement Time in H-mode Discharges*; Jun. 1991
- NIFS-94 H. Sanuki, K. Itoh, K. Ida and S. - I. Itoh, *On Radial Electric Field Structure in CHS Torsatron / Heliotron*; Jun. 1991
- NIFS-95 K. Itoh, H. Sanuki and S. - I. Itoh, *Influence of Fast Ion Loss on Radial Electric Field in Wendelstein VII-A Stellarator*; Jun. 1991

- NIFS-96 S. - I. Itoh, K. Itoh, A. Fukuyama, *ELMy-H mode as Limit Cycle and Chaotic Oscillations in Tokamak Plasmas*; Jun. 1991
- NIFS-97 K. Itoh, S. - I. Itoh, H. Sanuki, A. Fukuyama, *An H-mode-Like Bifurcation in Core Plasma of Stellarators*; Jun. 1991
- NIFS-98 H. Hojo, T. Watanabe, M. Inutake, M. Ichimura and S. Miyoshi, *Axial Pressure Profile Effects on Flute Interchange Stability in the Tandem Mirror GAMMA 10*; Jun. 1991
- NIFS-99 A. Usadi, A. Kageyama, K. Watanabe and T. Sato, *A Global Simulation of the Magnetosphere with a Long Tail : Southward and Northward IMF*; Jun. 1991
- NIFS-100 H. Hojo, T. Ogawa and M. Kono, *Fluid Description of Ponderomotive Force Compatible with the Kinetic One in a Warm Plasma* ; July 1991
- NIFS-101 H. Momota, A. Ishida, Y. Kohzaki, G. H. Miley, S. Ohi, M. Ohnishi K. Yoshikawa, K. Sato, L. C. Steinhauer, Y. Tomita and M. Tuszewski *Conceptual Design of D-³He FRC Reactor "ARTEMIS"* ; July 1991
- NIFS-102 N. Nakajima and M. Okamoto, *Rotations of Bulk Ions and Impurities in Non-Axisymmetric Toroidal Systems* ; July 1991
- NIFS-103 A. J. Lichtenberg, K. Itoh, S. - I. Itoh and A. Fukuyama, *The Role of Stochasticity in Sawtooth Oscillation* ; Aug. 1991
- NIFS-104 K. Yamazaki and T. Amano, *Plasma Transport Simulation Modeling for Helical Confinement Systems*; Aug. 1991
- NIFS-105 T. Sato, T. Hayashi, K. Watanabe, R. Horiuchi, M. Tanaka, N. Sawairi and K. Kusano, *Role of Compressibility on Driven Magnetic Reconnection* ; Aug. 1991
- NIFS-106 Qian Wen - Jia, Duan Yun - Bo, Wang Rong - Long and H. Narumi, *Electron Impact Excitation of Positive Ions - Partial Wave Approach in Coulomb - Eikonal Approximation* ; Sep. 1991
- NIFS-107 S. Murakami and T. Sato, *Macroscale Particle Simulation of Externally Driven Magnetic Reconnection*; Sep. 1991
- NIFS-108 Y. Ogawa, T. Amano, N. Nakajima, Y. Ohyabu, K. Yamazaki, S. P. Hirshman, W. I. van Rij and K. C. Shaing, *Neoclassical Transport Analysis in the Banana Regime on Large Helical Device (LHD) with the DKES Code*; Sep. 1991
- NIFS-109 Y. Kondoh, *Thought Analysis on Relaxation and General Principle to Find Relaxed State*; Sep. 1991
- NIFS-110 H. Yamada, K. Ida, H. Iguchi, K. Hanatani, S. Morita, O. Kaneko, H. C. Howe, S. P. Hirshman, D. K. Lee, H. Arimoto, M. Hosokawa, H. Idei, S. Kubo, K. Matsuoka, K. Nishimura, S. Okamura, Y. Takeiri, Y. Takita and C. Takahashi, *Shafranov Shift in Low-Aspect-Ratio Heliotron / Torsatron CHS* ; Sep 1991

- NIFS-111 R. Horiuchi, M. Uchida and T. Sato, *Simulation Study of Stepwise Relaxation in a Spheromak Plasma* ; Oct. 1991
- NIFS-112 M. Sasao, Y. Okabe, A. Fujisawa, H. Iguchi, J. Fujita, H. Yamaoka and M. Wada, *Development of Negative Heavy Ion Sources for Plasma Potential Measurement* ; Oct. 1991
- NIFS-113 S. Kawata and H. Nakashima, *Tritium Content of a DT Pellet in Inertial Confinement Fusion* ; Oct. 1991
- NIFS-114 M. Okamoto, N. Nakajima and H. Sugama, *Plasma Parameter Estimations for the Large Helical Device Based on the Gyro-Reduced Bohm Scaling* ; Oct. 1991
- NIFS-115 Y. Okabe, *Study of Au⁻ Production in a Plasma-Sputter Type Negative Ion Source* ; Oct. 1991
- NIFS-116 M. Sakamoto, K. N. Sato, Y. Ogawa, K. Kawahata, S. Hirokura, S. Okajima, K. Adati, Y. Hamada, S. Hidekuma, K. Ida, Y. Kawasumi, M. Kojima, K. Masai, S. Morita, H. Takahashi, Y. Taniguchi, K. Toi and T. Tsuzuki, *Fast Cooling Phenomena with Ice Pellet Injection in the JIPP T-IIU Tokamak*; Oct. 1991
- NIFS-117 K. Itoh, H. Sanuki and S. -I. Itoh, *Fast Ion Loss and Radial Electric Field in Wendelstein VII-A Stellarator*; Oct. 1991
- NIFS-118 Y. Kondoh and Y. Hosaka, *Kernel Optimum Nearly-analytical Discretization (KOND) Method Applied to Parabolic Equations <<KOND-P Scheme>>*; Nov. 1991
- NIFS-119 T. Yabe and T. Ishikawa, *Two- and Three-Dimensional Simulation Code for Radiation-Hydrodynamics in ICF*; Nov. 1991
- NIFS-120 S. Kawata, M. Shiromoto and T. Teramoto, *Density-Carrying Particle Method for Fluid* ; Nov. 1991
- NIFS-121 T. Ishikawa, P. Y. Wang, K. Wakui and T. Yabe, *A Method for the High-speed Generation of Random Numbers with Arbitrary Distributions*; Nov. 1991
- NIFS-122 K. Yamazaki, H. Kaneko, Y. Taniguchi, O. Motojima and LHD Design Group, *Status of LHD Control System Design* ; Dec. 1991
- NIFS-123 Y. Kondoh, *Relaxed State of Energy in Incompressible Fluid and Incompressible MHD Fluid* ; Dec. 1991
- NIFS-124 K. Ida, S. Hidekuma, M. Kojima, Y. Miura, S. Tsuji, K. Hoshino, M. Mori, N. Suzuki, T. Yamauchi and JFT-2M Group, *Edge Poloidal Rotation Profiles of H-Mode Plasmas in the JFT-2M Tokamak* ; Dec. 1991
- NIFS-125 H. Sugama and M. Wakatani, *Statistical Analysis of Anomalous Transport in Resistive Interchange Turbulence* ;Dec. 1991