

## §23. Workshop on "Development and Reactor Application of ICRF Heating Device"

Mutoh, T., Saito, K., Seki, T., Kasahara, H., Seki, R., Tokuzawa, T., Yanagi, N., Watanabe, T., Ozaki, T., Nomura, G., Kumazawa, R., Takase, Y., Ejiri, A., Shinya, T., Kamio, S. (Frontier Sci., Univ. Tokyo), Ichimura, M., Ikezoe, R., Yokoyama, T., Saito, Y. (Plasma Research Center, Tsukuba Univ.), Okada, H. (Institute of Advanced Energy, Kyoto Univ.), Murakami, S. (Eng., Kyoto Univ.)

Ion cyclotron range of frequencies (ICRF) heating is an important and promising heating method for future reactor relevant devices. The ion heating of high-density core plasma can be realized only by ICRF heating. Therefore we must develop technology for high power and reliable ICRF heating. To strengthen the development action, the second workshop was held on February 20th in 2013 in NIFS. Around 20 researchers and technical staff joined the workshop. We exchanged the information on the ICRF heating technology. The following topics were presented and discussed.

1. "Status of ICRF heating system and recent ICRF experiment in LHD" presented by T. Seki.

ICRF conditioning is useful for high  $T_i$  operation. The plasma of  $n_e=3.6 \times 10^{19} \text{ m}^{-3}$  was successfully sustained for 10 seconds with the RF power of 2.4MW, and the plasma of  $n_e=1.0 \times 10^{19} \text{ m}^{-3}$  was also successfully sustained for 19 minutes with the RF power of 1MW.

2. "Spontaneously excited waves and axial transport of high-energy ions in GAMMA10" presented by R. Ikezoe. Alfvén ion-cyclotron (AIC) waves are detected in GAMMA10. The spectrum of the AIC waves has several peaks as shown in Fig.1. It was cleared by using reflectometers in the central cell that the standing wave along axis exists. In the radial direction, there is the phase inversion surface. In the anchor cell the AIC waves were excited at the start-up phase and ICRF heating phase. AIC waves enhances the axial transport of high-energy particles, which was cleared with the particle detector attached at the end of GAMMA10.

3. "ICRF heating experiments in the minimum-B anchor cell on GAMMA10" presented by T. Yokoyama.

It was predicted by TASK WM code that the antenna-plasma coupling was much improved by the modification of ICRF antenna for anchor heating. The simulation agreed with the experimental result. It was also cleared that the plasma parameters were affected by the phasing between ICRF antennas in anchor cell and central cell.

4. "Development of high-power ICRF antenna in LHD" presented by K. Saito.

New ICRF antennas in LHD shown in Fig. 2 were developed. They have the optimized impedance transformer in the transmission line. Therefore high-power injection of 1.6MW/antenna is expected.

5. "Cyclotron resonance heating in LHD magnetic field configuration" presented by T. Watanabe.

Simulation showed that the heating efficiency depending on the resonance position in LHD by the comparison of three magnetic configuration. The efficiency is the highest when the resonance layer located on the axis at the horizontally elongated plasma cross-section. When the layer located at the saddle point of magnetic field at the vertically elongated plasma cross-section, the efficiency is the second highest. When the layer located at the magnetic axis at the cross-section, the efficiency is lowest.

6. "Wave measurements by a microwave reflectometer on LHD" presented by A.Ejiri.

A reflectometer near ICRF antenna was newly installed in LHD. The electric field of ICRF wave is the order of 1kV/m and it increases with the minor radius of cut-off position.

7. "ICRF wave analyses code (TASK/WM)" presented by R. Seki.

The status of full wave code TASK/WM was presented. ICRF wave is calculated with the collisional damping model.

We could share the useful information for the research on ICRF heating.

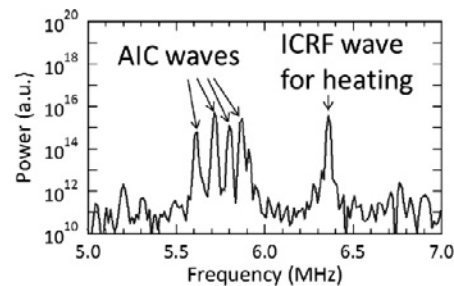

Fig. 1 AIC waves in GAMMA10

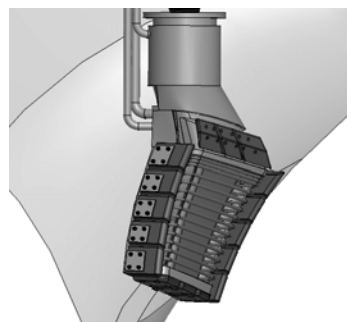

Fig. 2 New ICRF antenna in LHD