

§26. Development of a Helical Winding Using Advanced Superconductors for High Magnetic Fields

Nomura, S. (Meiji Univ.),
 Yagai, T. (Sophia Univ.),
 Nakamura, T. (Kyoto Univ.),
 Tsutsui, H. (Tokyo Tech.),
 Chikaraishi, H., Yanagi, N., Imagawa, S.

Nb_3Sn , Nb_3Al , and high temperature superconductors such as BSCCO and YBCO, are very promising for high field superconducting magnets. However, the mechanical stresses in these advanced superconductors lower their critical currents. Due to this, special considerations are required for the coil manufacturing processes. Especially, the windings of helical coils have three-dimensional complex shapes, meaning that it may be difficult to manufacture the helical windings without a decrease in the critical current.

The objective of this work is to establish the helical winding techniques without plastic deformations of the superconductors, and also evaluate the critical current dependence on the mechanical stresses caused by the shape of the helical windings. In this work, the research group focus on the feasibility of the helical windings using YBCO coated conductors.

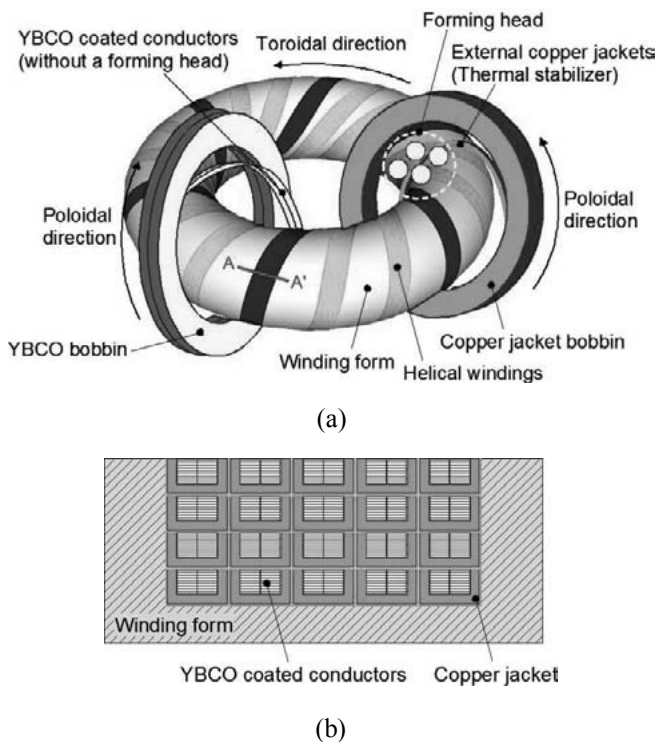

Fig. 1. Schematic illustration of the helical winding technique without plastic deformations of the YBCO coated conductors (a) and a schematic cross section of the helical windings (b).

Fig. 1 shows a schematic illustration of the helical winding technique without plastic deformation of the YBCO conductors. After the copper jacket, which is used for the thermal stabilizer, is formed into the shape of the helical winding, the YBCO conductors is wound onto the jacket in order to minimize the applied mechanical stresses during the winding process. In this work, the research group is planning to demonstrate the feasibility of the proposed winding technique by developing a model of the helical winding machine.

The research group is also planning to evaluate the critical current properties of the YBCO conductors against the mechanical stresses caused by the shape of the helical windings by developing the experimental equipment as shown in Fig. 2. During the winding process of the helical coils, the bending stresses, the tensile stresses and the torsional stresses will be composedly applied to the YBCO conductors. In order to simulate such helical winding conditions, this equipment will enable the evaluation of the critical current properties against the composed mechanical stresses including the exfoliation problems of the YBCO coated conductors. The obtained properties will feed back to the optimization of the helical winding techniques.

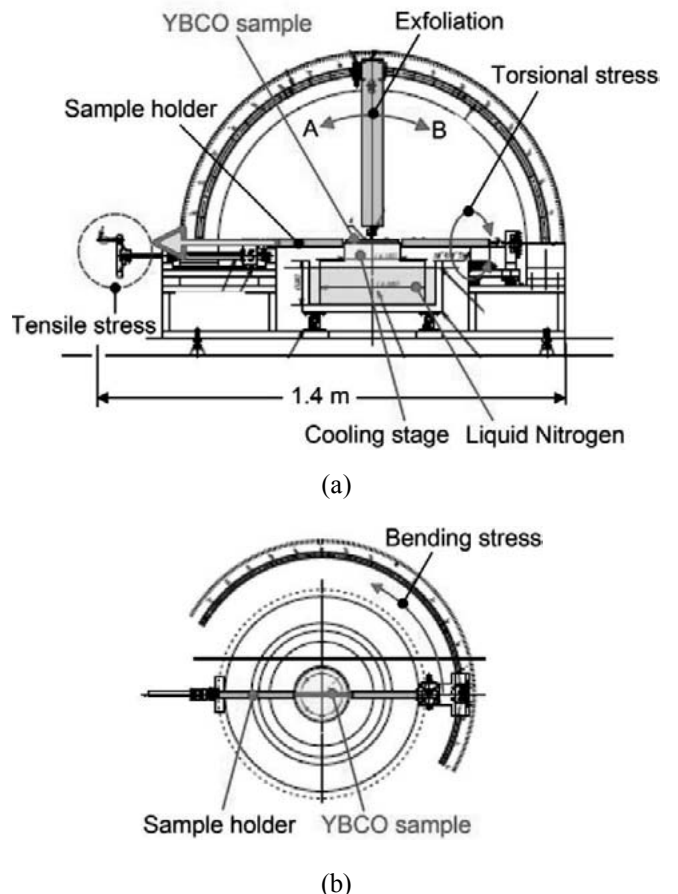

Fig. 2. Side view (a) and top view (b) of the experimental equipment for the evaluation of the critical current properties of the YBCO conductors against the mechanical stresses caused by the shape of the helical windings.