

# Linearized model collision operators for multiple ion species plasmas and gyrokinetic entropy balance equations

メタデータ	言語: English 出版者: 公開日: 2010-10-15 キーワード (Ja): キーワード (En): 作成者: Sugama, H., Watanabe, T.-H., Nunami, M. メールアドレス: 所属:
URL	<a href="http://hdl.handle.net/10655/3885">http://hdl.handle.net/10655/3885</a>

This work is licensed under a Creative Commons Attribution-NonCommercial-ShareAlike 3.0 International License.



# Linearized model collision operators for multiple ion species plasmas and gyrokinetic entropy balance equations

H. Sugama,<sup>1,2</sup> T.-H. Watanabe,<sup>1,2</sup> and M. Nunami<sup>1</sup>

<sup>1</sup>National Institute for Fusion Science, Toki 509-5292, Japan

<sup>2</sup>The Graduate University for Advanced Studies, Toki 509-5292, Japan

(Received 29 July 2009; accepted 12 October 2009; published online 4 November 2009)

Linearized model collision operators for multiple ion species plasmas are presented that conserve particles, momentum, and energy and satisfy adjointness relations and Boltzmann's H-theorem even for collisions between different particle species with unequal temperatures. The model collision operators are also written in the gyrophase-averaged form that can be applied to the gyrokinetic equation. Balance equations for the turbulent entropy density, the energy of electromagnetic fluctuations, the turbulent transport fluxes of particle and heat, and the collisional dissipation are derived from the gyrokinetic equation including the collision term and Maxwell equations. It is shown that, in the steady turbulence, the entropy produced by the turbulent transport fluxes is dissipated in part by collisions in the nonzonal-mode region and in part by those in the zonal-mode region after the nonlinear entropy transfer from nonzonal to zonal modes. © 2009 American Institute of Physics. [doi:10.1063/1.3257907]

## I. INTRODUCTION

Nowadays, kinetic theories and simulations are basic means which are extensively used to investigate transport processes in high-temperature plasmas.<sup>1,2</sup> Collisions are one of the important factors in the kinetic framework to determine plasma transport. In magnetically confined toroidal plasmas, Coulomb collisions are a main cause of the neoclassical transport,<sup>3,4</sup> which is investigated by using the drift kinetic equations. On the other hand, the turbulent transport is driven by plasma microinstabilities and it is described by the gyrokinetic equation,<sup>5</sup> which still needs a collision term for the steady turbulent state to be realized. Therefore, it is desirable to use a good collision model in the kinetic equations, which is easy to treat analytically or numerically but satisfies physically correct constraints such as conservation laws of particles, momentum, and energy.

A well-established collision term for collisions between particle species  $a$  and  $b$  is given by the Landau operator  $C_{ab}(f_a, f_b)$ ,<sup>6</sup> which is bilinear with respect to the distribution functions  $f_a$  and  $f_b$ , where the subscripts  $a$  and  $b$  represent the corresponding particle species. When the distribution functions are given by the sum of the equilibrium part  $f_{a0}$  and the small perturbation part  $\delta f_a$  as  $f_a = f_{a0} + \delta f_a$ , one often uses the linearized collision operator  $C_{ab}^L$  that is defined from  $C_{ab}$  by

$$C_{ab}^L(\delta f_a, \delta f_b) = C_{ab}(\delta f_a, f_{b0}) + C_{ab}(f_{a0}, \delta f_b), \quad (1)$$

where the first and second terms on the right-hand side represent the test- and field-particle collision operators, respectively. The equilibrium distribution function is assumed to take Maxwellian form,  $f_{a0} = f_{aM} \equiv (n_a / \pi^{3/2} v_{Ta}^3) \exp(-v^2 / v_{Ta}^2)$ , where  $n_a$  is the density,  $v_{Ta} \equiv (2T_a / m_a)^{1/2}$  is the thermal velocity,  $T_a$  is the temperature, and  $m_a$  is the particle mass for species  $a$ . Then, the test-particle collision term derived from the Landau operator is written as

$$C_{ab}(\delta f_a, f_{b0}) = \nu_D^{ab}(v) \mathcal{L} \delta f_a + C_v^{ab} \delta f_a + \frac{m_a}{T_b} \left(1 - \frac{T_b}{T_a}\right) \frac{1}{v^2} \frac{\partial}{\partial v} \left[ \frac{\nu_{\parallel}^{ab}(v)}{2} v^5 \delta f_a \right]. \quad (2)$$

Here,  $\mathcal{L}$  represents the pitch-angle-scattering operator defined by

$$\mathcal{L} \equiv \frac{1}{2} \frac{\partial}{\partial \mathbf{v}} \cdot (v^2 \mathbf{I} - \mathbf{v}\mathbf{v}) \cdot \frac{\partial}{\partial \mathbf{v}} = \frac{1}{2} \left( \frac{1}{\sin \theta} \frac{\partial}{\partial \theta} \sin \theta \frac{\partial}{\partial \theta} + \frac{1}{\sin^2 \theta} \frac{\partial^2}{\partial \varphi^2} \right), \quad (3)$$

where  $\mathbf{I}$  denotes the unit tensor and  $(v, \theta, \varphi)$  represent spherical coordinates in the velocity space. The operator  $C_v^{ab}$  in Eq. (2) is defined by

$$C_v^{ab} g \equiv \frac{1}{v^2} \frac{\partial}{\partial v} \left[ \frac{\nu_{\parallel}^{ab}(v)}{2} v^4 f_{aM} \frac{\partial}{\partial v} \left( \frac{g}{f_{aM}} \right) \right], \quad (4)$$

where  $g$  represents an arbitrary function of  $\mathbf{v}$ . The collision frequencies for pitch-angle scattering and energy diffusion are given by  $\nu_D^{ab}(v) \equiv (3\sqrt{\pi}/4) \tau_{ab}^{-1} [\Phi(x_b) - G(x_b)] / x_a^3$  and  $\nu_{\parallel}^{ab}(v) \equiv (3\sqrt{\pi}/2) \tau_{ab}^{-1} G(x_b) / x_a^3$ , respectively, where  $(3\sqrt{\pi}/4) \tau_{ab}^{-1} \equiv 4\pi n_b e_a^2 e_b^2 \ln \Lambda / (m_a^2 v_{Ta}^3)$  ( $\ln \Lambda$  is the Coulomb logarithm),  $\Phi(x) \equiv 2\pi^{-1/2} \int_0^x e^{-t^2} dt$ ,  $G(x) \equiv [\Phi(x) - x\Phi'(x)] / (2x^2)$ ,  $x_j \equiv v / v_{Tj}$ , and  $v_{Tj} \equiv (2T_j / m_j)^{1/2}$  ( $j = a, b$ ). From analytical and numerical points of view, the field-particle collision term  $C_{ab}(f_{a0}, \delta f_b)$  given by the Landau operator is more complicated than the test-particle collision term shown in Eq. (2) because laborious velocity-space integration is required.

Recently, Abel *et al.*<sup>7</sup> proposed linearized model collision operators for gyrokinetic simulations. Their like-particle-collision operators for the gyrokinetic equations are derived from the gyrophase average of the same test- and field-particle collision operators as used by Lin *et al.*<sup>8</sup> and Wang *et al.*<sup>9</sup> for  $\delta f$  simulations of neoclassical transport

caused by ion-ion collisions. The test-particle collision operator used by these authors is the exact one  $C_{aa}(\delta f_a, f_{a0})$  given by Eq. (2) for  $a=b$  while their field-particle collision operator is derived approximately such that particles, momentum, and energy are conserved. In addition, their linearized model collision operators for like-particle collisions are self-adjoint and obey Boltzmann's H-theorem in contrast with other models.<sup>10–12</sup> The self-adjointness and the H-theorem are also satisfied by the approximate test- and field-particle collision operators presented by Hirshman and Sigmar<sup>13</sup> although, as pointed out by Abel *et al.*,<sup>7</sup> the energy-diffusion process included in the exact Landau test-particle collision operator (but dropped in the Hirshman–Sigmar model operator) plays an important role in the damping of fine velocity-space structures appearing in the turbulent distribution function.

From the viewpoint of applications to practical cases, it is now natural to consider the model operator for collisions between different particle species in plasmas including multiple ion species. The established model operators for collisions between electrons and ions are available because the approximation is well justified by the small ratio of the electron mass  $m_e$  to the ion mass  $m_i$ . Besides, because of this small ratio,  $m_e/m_i \ll 1$ , the temperatures of electrons and ions are allowed to be unequal,  $T_e \neq T_i$ . When there exist multiple ion species and their masses are very different, they may have unequal temperatures, too. In the present work, we derive the linearized model collision operator which can be used even for collisions between different species of ions with unequal temperatures. For the unequal-temperature case, we find that the linearized Landau collision operators does not rigorously satisfy the adjointness relations and the H-theorem because of the last term proportional to  $(1 - T_b/T_a)$  appearing in the right-hand side of Eq. (2). However, these relations and theorem are very favorable for analytical and numerical studies of the kinetic equations with the collision term. For example, the adjointness relations are essential for the variational formulation of the solution to the drift kinetic equation<sup>14</sup> as well as for the Onsager symmetry of the classical and neoclassical transport matrices.<sup>3,4,6,15,16</sup>

The H-theorem implies the asymptotic relaxation of the distribution function to the local equilibrium state. Therefore, the approximate linearized operator is desired to keep the adjointness relations and the H-theorem in addition to the other conservation laws. These requirements are fulfilled in this work.

In this paper, we also discuss the steady turbulence which is subject to the entropy balance<sup>17,18</sup> between the production terms due to turbulent transport fluxes and the collisional dissipation based on the gyrokinetic equation with the gyrophase-averaged collision operator. Recently, as an attractive mechanism for regulation of turbulent transport, zonal flows,<sup>19–21</sup> which are the  $\mathbf{E} \times \mathbf{B}$  flows produced by electrostatic potential fluctuations with the wave number vectors in the direction perpendicular to flux surfaces, have been studied intensively by gyrokinetic turbulence simulations.<sup>1,2,22,23</sup> Therefore, it is instructive to discuss the role of such fluctuations with zonal structures from the viewpoint of the entropy balance. Using the entropy balance equations for the gyroki-

netic turbulence, we can identify the nonlinear term representing the entropy transfer from nonzonal to zonal modes, which is expressed in the fluid limit by the product of the well-known Reynolds stress and the flow shear.

The rest of this paper is organized as follows. In Sec. II, properties which should be satisfied by linearized collision operators such as conservation laws, adjointness relations, and the H-theorem are shown. In Sec. III, approximate electron-ion and ion-electron collision operators are examined about the validity of the properties shown in Sec. II. This close examination is useful to present the linearized model collision operators in Sec. IV, where the model operators are constructed such that the above-mentioned properties are satisfied even when two particle species involved in collisions have different background temperatures because of their mass difference. In Sec. V, the gyrophase-averaged form of the model collision operator is derived for application to the gyrokinetic equation. Then, based on the H-theorem satisfied by the collision operator, the entropy balance in the gyrokinetic turbulence is investigated in Sec. VI, where the balance among the entropy production associated with the turbulent particle and heat transport, the collisional dissipation, and the nonlinear entropy transfer from the nonzonal to zonal modes are discussed. Finally, conclusions are given in Sec. VII.

## II. PROPERTIES OF THE LINEARIZED COLLISION OPERATOR

In this section, several properties satisfied by the linearized Landau operator for collisions between species  $a$  and  $b$  are given in such a way as to show explicitly what conditions are satisfied by each of the test-particle part  $C_{ab}^T(\delta f_a) \equiv C_{ab}(\delta f_a, f_{b0})$  and the field-particle part  $C_{ab}^F(\delta f_b) \equiv C_{ab}(f_{a0}, \delta f_b)$ . Relations shown below hold in both cases of  $a=b$  and  $a \neq b$ .

Conservation of particles is separately satisfied by the test- and field-particle parts as

$$\int d^3v C_{ab}^T(\delta f_a) = \int d^3v C_{ab}^F(\delta f_b) = 0, \quad (5)$$

while the momentum conservation,

$$\int d^3v m_a \mathbf{v} C_{ab}^T(\delta f_a) + \int d^3v m_b \mathbf{v} C_{ba}^F(\delta f_b) = 0, \quad (6)$$

and the energy conservation,

$$\int d^3v \frac{1}{2} m_a v^2 C_{ab}^T(\delta f_a) + \int d^3v \frac{1}{2} m_b v^2 C_{ba}^F(\delta f_b) = 0, \quad (7)$$

hold when both parts are simultaneously included. Now, from the Galilean invariance and spherical symmetry of the collision operator, we have an identity,  $\int d^3v m_a(\mathbf{v} - \mathbf{u}) C_{ab}[f_{aM}(\mathbf{v} - \mathbf{u}), f_{bM}(\mathbf{v} - \mathbf{u})] = \int d^3v m_a \mathbf{v} C_{ab}[f_{aM}(\mathbf{v}), f_{bM}(\mathbf{v})] = 0$ , for an arbitrary vector  $\mathbf{u}$  which is independent of  $\mathbf{v}$ . Then, taking the  $\mathbf{u} \rightarrow 0$  limit of the above identity and using Eqs. (5) and (6), we can derive useful relations written as

$$\begin{aligned}
& \int d^3v m_a \mathbf{v} C_{ab}^T (f_{aM} m_a \mathbf{v} / T_a) \\
&= \int d^3v m_b \mathbf{v} C_{ba}^T (f_{bM} m_b \mathbf{v} / T_b) \\
&= - \int d^3v m_a \mathbf{v} C_{ab}^F (f_{bM} m_b \mathbf{v} / T_b) \\
&= - \int d^3v m_b \mathbf{v} C_{ba}^F (f_{aM} m_a \mathbf{v} / T_a). \tag{8}
\end{aligned}$$

It should be noted that Eq. (8) is satisfied even when  $T_a \neq T_b$ .

The adjointness relations for the test- and field-particle collision operators are given by

$$\int d^3v \frac{\delta f_a}{f_{aM}} C_{ab}^T (\delta g_a) = \int d^3v \frac{\delta g_a}{f_{aM}} C_{ab}^T (\delta f_a), \tag{9}$$

$$T_a \int d^3v \frac{\delta f_a}{f_{aM}} C_{ab}^F (\delta f_b) = T_b \int d^3v \frac{\delta f_b}{f_{bM}} C_{ba}^F (\delta f_a).$$

As shown by Rosenbluth, Hazeltine, and Hinton,<sup>14</sup> the solution of the linearized drift kinetic equation with the collision term satisfying the adjoint relations in Eq. (9) can be obtained from the variational principle for any collisional regime. Besides, the Onsager symmetry of the classical and neoclassical transport matrices is derived from the adjoint relations.<sup>3,4,6,15,16</sup> From the facts mentioned above, the adjointness relations in Eq. (9) are important and useful especially for treating the problems of collisional transport correctly.

The H-theorem is written as

$$\begin{aligned}
& T_a \int d^3v \frac{\delta f_a}{f_{aM}} [C_{ab}^T (\delta f_a) + C_{ab}^F (\delta f_b)] \\
&+ T_b \int d^3v \frac{\delta f_b}{f_{bM}} [C_{ba}^T (\delta f_b) + C_{ba}^F (\delta f_a)] \leq 0. \tag{10}
\end{aligned}$$

In Eq. (10), the equality is satisfied only when

$$\begin{aligned}
\delta f_a &= f_{aM} \left[ \frac{\delta n_a}{n_a} + \frac{m_a}{T_a} \mathbf{u}_a \cdot \mathbf{v} + \frac{\delta T_a}{T_a} \left( \frac{m_a v^2}{2T_a} - \frac{3}{2} \right) \right], \\
\delta f_b &= f_{bM} \left[ \frac{\delta n_b}{n_b} + \frac{m_b}{T_b} \mathbf{u}_b \cdot \mathbf{v} + \frac{\delta T_b}{T_b} \left( \frac{m_b v^2}{2T_b} - \frac{3}{2} \right) \right], \tag{11}
\end{aligned}$$

where  $\mathbf{u}_a = \mathbf{u}_b$  and  $\delta T_a / T_a = \delta T_b / T_b$ . The H-theorem shown in Eqs. (10) and (11) describes irreversible or dissipative nature of collisions which cause the distribution function to asymptotically approach the local equilibrium state. From the viewpoint of kinetic simulation to evaluate plasma transport in the steady turbulence, the H-theorem is useful in that it gives the basis of a necessary damping mechanism for the turbulent distribution function which is driven away from the equilibrium by instabilities.

Strictly speaking, the adjointness relations and the H-theorem described by Eqs. (9)–(11) are satisfied by the linearized Landau collision operator only for the case of  $T_a = T_b$ . As seen from the case of collisions between electrons

and ions in Sec. III, when  $T_a \neq T_b$  and  $m_a \ll m_b$ , the adjointness relations written in Eq. (9) are valid up to the lowest order of the expansion in  $(m_a/m_b)^{1/2}$ . On the other hand, when  $m_a \gg m_b$ , the test-particle part  $C_{ab}^T$  of the Landau collision operator shown in Eq. (2) contains the term proportional to  $(1 - T_b/T_a)$  that gives an error to the first adjointness relation in Eq. (9) and the H-theorem in Eq. (10). The magnitude of this error in  $C_a^T$  does not decrease as  $m_b/m_a$  decreases. However, the relative magnitude of the error in the sum of the collision operators  $C_{aa}^T (\delta f_a) + C_{ab}^T (\delta f_a)$  are of the order of  $(n_b/n_a)(e_b/e_a)^2(m_b/m_a)^{1/2}(1 - T_b/T_a)$ . Therefore, when  $(m_b/m_a)^{1/2}(1 - T_b/T_a)$  is small enough, the term contained in  $C_{ab}^T (\delta f_a)$ , which breaks the relations in Eqs. (9) and (10), can be neglected without influencing the solution  $\delta f_a$  of the collisional kinetic equation. Furthermore, we find from Eq. (8) that, even for  $T_a \neq T_b$ , the adjointness relations in Eq. (9) and the H-theorem written in Eqs. (10) and (11) are all valid for an arbitrary mass ratio  $m_a/m_b$ , when  $\delta f_a$ ,  $\delta f_b$ ,  $\delta g_a$ , and  $\delta g_b$  are given in the shifted Maxwellian form,  $f_{sM}[\delta n_s/n_0 + (m_s/T_s)\mathbf{u}_s \cdot \mathbf{v}]$  ( $s = a, b$ ).

### III. ELECTRON-ION AND ION-ELECTRON COLLISION OPERATORS

It is instructive to revisit the approximate operators for electron-ion and ion-electron collisions here before proceeding to the next section where we consider model collision operators for general cases of collisions between different species. The collisional exchange of energy between electrons and ions occurs slowly because of the small electron-ion mass ratio  $m_e/m_i \ll 1$ . Therefore, the equilibrium electron and ion distribution functions generally can be assumed to take the Maxwellian forms with different temperatures,  $T_e \neq T_i$ . The approximate electron-ion and ion-electron collision operators<sup>6,14</sup> are obtained by using  $(m_e/m_i)^{1/2}$  as an expansion parameter.

For electron-ion collisions, we can still neglect  $C_{ei}(f_{eM}, f_{iM})$ . The linearized electron-ion collision operator is given by

$$C_{ei}^L(\delta f_e, \delta f_i) = C_{ei}^T(\delta f_e) + C_{ei}^F(\delta f_i), \tag{12}$$

where the test- and field-particle collision parts are written as

$$C_{ei}^T(\delta f_e) = \nu_D^{ei} \mathcal{L} \delta f_e, \tag{13}$$

$$C_{ei}^F(\delta f_i) = \nu_D^{ei} \frac{m_e}{T_e} \mathbf{u}_i [\delta f_i] \cdot \mathbf{v} f_{eM},$$

where  $\mathbf{u}_i [\delta f_i] \equiv n_i^{-1} \int d^3v \delta f_i \mathbf{v}$  represents the ion flow velocity. On the right-hand side of Eq. (13) shown are the lowest-order terms in the expansion with respect to  $(m_e/m_i)^{1/2}$ . The neglected terms there are smaller by the factor of  $(m_e/m_i)^{1/2}$  than the lowest-order terms.

Using  $m_e/m_i \ll 1$ , the ion-electron collision operator can also be expressed in the simplified form,

$$C_{ie}(f_i, f_e) = -\frac{\mathbf{F}_{ei} \cdot \mathbf{v}}{n_i T_i} f_{iM} + \frac{1}{\tau_{ei}} \frac{n_e m_e}{n_i m_i} \frac{\partial}{\partial \mathbf{v}} \cdot \left[ (\mathbf{v} - \mathbf{u}_i) f_i + \frac{T_e}{m_i} \frac{\partial f_i}{\partial \mathbf{v}} \right] \\ = C_{ie}(f_{iM}, f_{eM}) + C_{ie}^L(\delta f_i, \delta f_e) + \mathcal{O}[(\delta f_i)^2], \quad (14)$$

where  $\mathbf{F}_{ei} \equiv -\int d^3v \delta f_e v_D^{ei}(v) m_e \mathbf{v} + n_e m_e \mathbf{u}_i / \tau_{ei}$  represents the electron-ion collisional friction force and

$$C_{ie}(f_{iM}, f_{eM}) = \frac{2f_{iM} n_e m_e}{\tau_{ei} n_i m_i} \left( \frac{T_e}{T_i} - 1 \right) \left( x_i^2 - \frac{3}{2} \right) \quad (15)$$

describes the slow collisional energy exchange between ions and electrons. Here,  $x_i^2 \equiv m_i v^2 / 2T_i$ . The linearized ion-electron collision operator is derived from Eq. (14) as

$$C_{ie}^L(\delta f_i, \delta f_e) = C_{ie}^T(\delta f_i) + C_{ie}^F(\delta f_e), \quad (16)$$

where the test- and field-particle collision parts are written as

$$C_{ie}^T(\delta f_i) = \frac{1}{\tau_{ei}} \frac{n_e m_e}{n_i m_i} \left[ \frac{T_e}{m_i} \frac{\partial}{\partial \mathbf{v}} \cdot \left\{ f_{iM} \frac{\partial}{\partial \mathbf{v}} \left( \frac{\delta f_i}{f_{iM}} \right) \right\} \right. \\ \left. + \left( 1 - \frac{T_e}{T_i} \right) \frac{\partial}{\partial \mathbf{v}} \cdot (\delta f_i \mathbf{v}) \right] \quad (17)$$

and

$$C_{ie}^F(\delta f_e) = \frac{f_{iM} \mathbf{v}}{n_i T_i} \cdot \int d^3v \delta f_e v_D^{ei}(v) m_e \mathbf{v}, \quad (18)$$

respectively. In the first line of Eq. (14), the  $(m_e/m_i)^{1/2}$ -expansion is used and the neglected terms are smaller by the factor of  $(m_e/m_i)^{1/2}$  than the explicitly shown terms. Substituting  $f_i = f_{i0} + \delta f_i$  there and noting that  $\mathbf{u}_i = \mathbf{u}_i[\delta f_i]$  is the first-order quantity in  $\delta f_i$ , we find that  $-(1/\tau_{ei})(n_e m_e/n_i m_i)(\partial/\partial \mathbf{v}) \cdot (\mathbf{u}_i \delta f_i)$  becomes the second-order quantity,  $\mathcal{O}[(\delta f_i)^2]$ , as shown at the end of Eq. (14).

It is easy to verify that the electron-ion and ion-electron collision operators given by Eqs. (13), (17), and (18) satisfy particle and momentum conservation laws, Eqs. (5) and (6). As for the energy conservation laws, these approximate operators in Eqs. (13), (17), and (18) satisfy Eq. (7) for the case of  $(a, b) = (e, i)$  but break Eq. (7) for  $(a, b) = (i, e)$  as seen from the fact that  $\int d^3v (1/2) m_i v^2 C_{ie}^T(\delta f_i) = -(3/\tau_{ei}) \times (n_e m_e/n_i m_i) \int d^3v \delta f_i (m_i v^2/3 - T_e)$  ( $\neq 0$  generally) and  $\int d^3v (1/2) m_e v^2 C_{ie}^F(\delta f_e) = 0$  are derived from using  $C_{ie}^T(\delta f_i)$  in Eq. (17) and  $C_{ie}^F(\delta f_e)$  in Eq. (13), respectively. We note that Eqs. (13) and (17) both contain the only leading-order terms of in the  $(m_e/m_i)^{1/2}$ -expansion although these terms describe collisional processes on different time scales. The collisional energy exchange between ions and electrons described by Eq. (17) occurs on a much-longer time scale  $(m_i/m_e)\tau_{ei}$  than the scale of the electron-ion collision time  $\tau_{ei}$  treated by Eq. (13). Therefore, in order to recover the energy conservation in this slow process, we need to keep higher-order terms neglected by  $C_{ie}^F(\delta f_e)$  in Eq. (13).

Regarding the adjointness relations given in Eq. (9), they hold for the operators  $C_{ei}^T$ ,  $C_{ei}^F$ , and  $C_{ie}^F$  defined by Eqs. (13) and (18), although the test-particle operator  $C_{ie}^T$  defined in Eq. (17) does not satisfy Eq. (9) when  $T_i \neq T_e$ . Since  $C_{ie}^T$  is necessary for the collisional momentum conservation, it cannot be simply neglected. In the neoclassical transport theory by Rosenbluth, Hazeltine, and Hinton,<sup>14</sup> only the first term

$-(\mathbf{F}_{ei} \cdot \mathbf{v}/n_i T_i) f_{iM}$  of the first line in Eq. (14) is kept in  $C_{ie}$ . This corresponds to replacing  $C_{ie}^T$  with its momentum-transfer part,  $\tilde{C}_{ie}^T(\delta f_i) \equiv -(n_e m_e/n_i T_i \tau_{ei}) \mathbf{u}_i[\delta f_i] \cdot \mathbf{v} f_{iM}$ . Since this approximate test-particle operator for ion-electron collisions is self-adjoint even for  $T_i \neq T_e$ , the variational method based on the self-adjoint properties can be applied to calculation of the neoclassical transport coefficients. We should note that the terms neglected in reducing  $C_{ie}^T$  to  $\tilde{C}_{ie}^T$  have the magnitude of the same order as  $\tilde{C}_{ie}^T$  although they are smaller than  $C_{ii}$  by the factor of  $(m_e/m_i)^{1/2}$ .

In the rest of this section, we consider an improved approximation of  $C_{ie}^T$  in Eq. (17) by keeping the whole energy-diffusion term and replacing the last term proportional to  $(1 - T_e/T_i)$  on the right-hand side of Eq. (17) with

$$-\frac{f_{aM} n_e m_e}{\tau_{ei} n_i m_i} \left( 1 - \frac{T_e}{T_i} \right) \left\{ \frac{m_i}{T_i} \mathbf{u}_i[\delta f_i] \cdot \mathbf{v} \right. \\ \left. + 2 \left( \frac{\delta n_i[\delta f_i]}{n_i} + \frac{\delta T_i[\delta f_i]}{T_i} \right) \left( x_i^2 - \frac{3}{2} \right) \right\}, \quad (19)$$

which conserves the particle number and gives the same transfer rates of momentum and energy as the original term. Here,  $\delta n_i[\delta f_i] \equiv \int d^3v \delta f_i$ ,  $\mathbf{u}_i[\delta f_i] \equiv n_i^{-1} \int d^3v \delta f_i \mathbf{v}$ , and  $\delta T_i[\delta f_i]/T_i \equiv n_i^{-1} \int d^3v \delta f_i \mathbf{v} (m_i v^2/3T_i - 1)$ . Now, the new test-particle operator  $C_{ie}^{TS}$  for ion-electron collisions is given by

$$C_{ie}^{TS}(\delta f_i) \\ = \frac{1}{\tau_{ei}} \frac{n_e m_e}{n_i m_i} \left[ \frac{T_e}{m_i} \frac{\partial}{\partial \mathbf{v}} \cdot \left\{ f_{iM} \frac{\partial}{\partial \mathbf{v}} \left( \frac{\delta f_i}{f_{iM}} \right) \right\} \right. \\ \left. - f_{iM} \left( 1 - \frac{T_e}{T_i} \right) \left\{ \frac{m_i}{T_i} \mathbf{u}_i[\delta f_i] \cdot \mathbf{v} + 2 \frac{\delta T_i[\delta f_i]}{T_i} \left( x_i^2 - \frac{3}{2} \right) \right\} \right], \quad (20)$$

where  $C_{ie}^T(f_{iM} \delta n_i[\delta f_i]/n_i)$  is subtracted from  $C_{ie}^T(\delta f_i)$  in order to guarantee that  $C_{ie}^{TS}(\delta f_i)$  vanishes when  $\delta f_i$  takes the Maxwellian form,  $\delta f_i = (\delta n_i[\delta f_i]/n_i) f_{iM}$ . The energy-diffusion is still retained in Eq. (20) and  $C_{ie}^{TS}$  coincides with  $C_{ie}^T$  if  $T_i = T_e$ . Now, it is important to note that  $C_{ie}^{TS}$  satisfies the self-adjointness condition,  $\int d^3v (g/f_{iM}) C_{ie}^{TS}(h) = \int d^3v (h/f_{iM}) \times C_{ie}^{TS}(g)$ , as the aforementioned approximate test-particle operator  $\tilde{C}_{ie}^T(\delta f_i) \equiv -(n_e m_e/n_i T_i \tau_{ei}) \mathbf{u}_i[\delta f_i] \cdot \mathbf{v} f_{iM}$  does. This self-adjointness of  $C_{ie}^{TS}$  is more evidently seen when we rewrite Eq. (20) as

$$C_{ie}^{TS}(\delta f_i) = \frac{1}{\tau_{ei}} \frac{n_e m_e T_e}{n_i m_i m_i} Q_{ie} \frac{\partial}{\partial \mathbf{v}} \cdot \left\{ f_{iM} \frac{\partial}{\partial \mathbf{v}} \left( \frac{Q_{ie} \delta f_i}{f_{iM}} \right) \right\}, \quad (21)$$

where the operator  $Q_{ie}$  is defined by

$$Q_{ie} g \equiv g + [(T_i/T_e)^{1/2} - 1] (\mathcal{P}_{1i} g + \mathcal{P}_{2i} g). \quad (22)$$

Here,  $g$  is an arbitrary function of  $\mathbf{v}$ . The projection operators  $\mathcal{P}_{1i}$  and  $\mathcal{P}_{2i}$  are defined by

$$\begin{aligned}\mathcal{P}_{1i}g &\equiv f_{iM} \frac{m_i}{T_i} \mathbf{u}_i[g] \cdot \mathbf{v}, \\ \mathcal{P}_{2i}g &\equiv f_{iM} \frac{\delta T_i[g]}{T_i} \left( x_i^2 - \frac{3}{2} \right),\end{aligned}\quad (23)$$

where  $\mathbf{u}_i[g] \equiv n_i^{-1} \int d^3v \delta f_i \mathbf{v}$ , and  $\delta T_i[g]/T_i \equiv n_i^{-1} \int d^3v (m_i v^2 / 3T_i - 1)g(\mathbf{v})$ . These projection operators satisfy the conditions,  $(\mathcal{P}_{1i})^2 = \mathcal{P}_{1i}$ ,  $(\mathcal{P}_{2i})^2 = \mathcal{P}_{2i}$ , and  $\mathcal{P}_{1i}\mathcal{P}_{2i} = \mathcal{P}_{2i}\mathcal{P}_{1i} = 0$ . We easily find that  $\mathcal{P}_{1i}$ ,  $\mathcal{P}_{2i}$ ,  $\mathcal{Q}_{ie}$ , and accordingly  $C_{ie}^{TS}$  are self-adjoint adjoint operators. Then, we can also show

$$\begin{aligned}\int d^3v \frac{\delta f_i}{f_{iM}} C_{ie}^{TS}(\delta f_i) \\ = -\frac{1}{\tau_{ei}} \frac{n_e m_e T_e}{n_i m_i m_i} \int d^3v f_{iM} \left| \frac{\partial}{\partial \mathbf{v}} \left( \frac{\mathcal{Q}_{ie} \delta f_i}{f_{iM}} \right) \right|^2 \leq 0,\end{aligned}\quad (24)$$

which is a desirable condition corresponding to a limited version of the H-theorem shown in Eq. (10). The necessary and sufficient condition for  $\int d^3v (\delta f_i / f_{iM}) C_{ie}^{TS}(\delta f_i) = 0$  is given by  $\delta f_i = f_{iM} \delta n_i [\delta f_i / n_i]$ .

The self-adjoint test-particle operator for ion-electron collisions shown in Eq. (21) becomes a useful reference for the next section, where we present the model collision operators which satisfy the adjointness properties as well as the conservation laws even for collisions between different species with unequal temperatures.

#### IV. LINEARIZED MODEL COLLISION OPERATORS

We now consider the linearized collision operator for collisions between species  $a$  and  $b$ ,

$$C_{ab}^L(\delta f_a, \delta f_b) = C_{ab}^T(\delta f_a) + C_{ab}^F(\delta f_b).\quad (25)$$

Here, species  $a$  and  $b$  are allowed to have different temperatures,  $T_a \neq T_b$ , when the difference between  $m_a$  and  $m_b$  is large as in the case of the electron-ion or ion-electron collisions. When  $T_a \neq T_b$ , the rigorous test-particle operator given by Eq. (2) contains the part proportional to  $(1 - T_b/T_a)$ , which breaks the self-adjointness. Then, as explained in the previous section, we aim to reduce the test-particle operator to the form for which the self-adjointness is recovered.

We now follow the way similar to the one in deriving the self-adjoint operator  $C_{ie}^{TS}$  from  $C_{ie}^T$ , and modify the test-particle operator  $C_{ab}^T$  into the self-adjoint form,

$$C_{ab}^T(\delta f_a) = \mathcal{Q}_{ab} C_{ab}^{T0} \mathcal{Q}_{ab} \delta f_a.\quad (26)$$

Here,  $C_{ab}^{T0}$  is given by

$$C_{ab}^{T0}(g) \equiv \nu_D^{ab} \mathcal{L}(g) + C_v^{ab}(g),\quad (27)$$

where  $\mathcal{L}$  and  $C_v^{ab}$  are defined in Eqs. (3) and (4), respectively, and  $g$  represents an arbitrary function of  $\mathbf{v}$ . The operator  $\mathcal{Q}_{ab}$  is defined by

$$\mathcal{Q}_{ab}g \equiv g + (\theta_{ab} - 1)(\mathcal{P}_{1a}g + \mathcal{P}_{2a}g),\quad (28)$$

where the dimensionless parameter  $\theta_{ab}$  is given by

$$\theta_{ab} \equiv \left[ \frac{T_a \left( \frac{1}{m_a} + \frac{1}{m_b} \right)}{\left( \frac{T_a}{m_a} + \frac{T_b}{m_b} \right)} \right]^{1/2}.\quad (29)$$

The projection operators  $\mathcal{P}_{1a}$  and  $\mathcal{P}_{2a}$  are defined by

$$\begin{aligned}\mathcal{P}_{1a}g &\equiv f_{aM} \frac{m_a}{T_a} \mathbf{u}_a[g] \cdot \mathbf{v}, \\ \mathcal{P}_{2a}g &\equiv f_{aM} \frac{\delta T_a[g]}{T_a} \left( x_a^2 - \frac{3}{2} \right),\end{aligned}\quad (30)$$

where  $\mathbf{u}_a[g] \equiv n_a^{-1} \int d^3v \delta f_a \mathbf{v}$ ,  $\delta T_a[g]/T_a \equiv n_a^{-1} \int d^3v (m_a v^2 / 3T_a - 1)g(\mathbf{v})$ , and  $x_a^2 \equiv m_a v^2 / 2T_a$ . These projection operators satisfy the conditions,  $(\mathcal{P}_{1a})^2 = \mathcal{P}_{1a}$ ,  $(\mathcal{P}_{2a})^2 = \mathcal{P}_{2a}$ , and  $\mathcal{P}_{1a}\mathcal{P}_{2a} = \mathcal{P}_{2a}\mathcal{P}_{1a} = 0$ .

The definition of  $\theta_{ab}$  is such that Eq. (26) gives exactly the same value of  $\int d^3v m_a \mathbf{v} C_{ab}^T(f_{aM} \mathbf{v} / T_a)$  as Eq. (2) does [see Eqs. (8) and (40)]. When  $T_a = T_b$ , Eq. (26) coincides with Eq. (2) because  $\theta_{ab} = 1$  and  $\mathcal{Q}_{ab}(g) = g$  for that case. We see that, even if  $T_a \neq T_b$ , the operator  $C_v^{ab}$  satisfies the self-adjointness condition,  $\int d^3v (g / f_{aM}) C_v^{ab}(h) = \int d^3v (h / f_{aM}) C_v^{ab}(g)$ , as  $\mathcal{L}$  does. Moreover,  $\mathcal{P}_{ab}$ ,  $\mathcal{Q}_{ab}$ ,  $C_{ab}^{T0}$ , and  $C_{ab}^T$  given by Eq. (26) are self-adjoint, too.

Equation (26) can be rewritten as

$$\begin{aligned}C_{ab}^T(\delta f_a) &= C_{ab}^{T0}(\delta f_a) + (\theta_{ab} - 1)(\mathcal{P}_a C_{ab}^{T0} \delta f_a + C_{ab}^{T0} \mathcal{P}_a \delta f_a) \\ &\quad + (\theta_{ab} - 1)^2 \mathcal{P}_a C_{ab}^{T0} \mathcal{P}_a \delta f_a,\end{aligned}\quad (31)$$

where  $\mathcal{P}_a \equiv \mathcal{P}_{1a} + \mathcal{P}_{2a}$ ,

$$\begin{aligned}\mathcal{P}_a C_{ab}^{T0} \delta f_a &= f_{aM} \left[ \frac{m_a}{T_a} \mathbf{v} \cdot \frac{1}{n_a} \int d^3v \frac{\delta f_a}{f_{aM}} C_{ab}^{T0}(f_{aM} \mathbf{v}) \right. \\ &\quad \left. + \left( x_a^2 - \frac{3}{2} \right) \frac{1}{n_a} \int d^3v \frac{\delta f_a}{f_{aM}} \frac{2}{3} C_{ab}^{T0}(f_{aM} x_a^2) \right],\end{aligned}$$

$$C_{ab}^{T0} \mathcal{P}_a \delta f_a = \frac{m_a}{T_a} \mathbf{u}_a[\delta f_a] \cdot C_{ab}^{T0}(f_{aM} \mathbf{v}) + \frac{\delta T_a[\delta f_a]}{T_a} C_{ab}^{T0}(f_{aM} x_a^2),\quad (32)$$

$$\begin{aligned}\mathcal{P}_a C_{ab}^{T0} \mathcal{P}_a \delta f_a &= f_{aM} \left[ \frac{m_a}{T_a} \mathbf{u}_a[\delta f_a] \cdot \mathbf{v} \frac{1}{n_a} \int d^3v \frac{m_a \mathbf{v}}{3T_a} \cdot C_{ab}^{T0}(f_{aM} \mathbf{v}) \right. \\ &\quad \left. + \frac{\delta T_a[\delta f_a]}{T_a} \left( x_a^2 - \frac{3}{2} \right) \frac{1}{n_a} \int d^3v \frac{2}{3} x_a^2 C_{ab}^{T0}(f_{aM} x_a^2) \right].\end{aligned}$$

For evaluating Eq. (32), we use

$$\begin{aligned} C_{ab}^{T0}(f_{aM}\mathbf{v}) &= -(1 + \alpha_{ab}^2)f_{aM}v_{\parallel}^{ab}x_a^2\mathbf{v} \\ &= -\frac{3\sqrt{\pi}}{4}(1 + \alpha_{ab}^2)\frac{f_{aM}\mathbf{v}}{\tau_{ab}}\frac{2G(\alpha_{ab}x_a)}{x_a}, \end{aligned}$$

$$\begin{aligned} C_{ab}^{T0}(f_{aM}x_a^2) &= C_v^{ab}(f_{aM}x_a^2) \\ &= \frac{1}{x_a^2}\frac{d}{dx_a}(v_{\parallel}^{ab}x_a^5f_{aM}) \\ &= -\frac{3\sqrt{\pi}}{4\tau_{ab}}f_{aM}\frac{2}{\alpha_{ab}^2x_a}[\Phi(\alpha_{ab}x_a) \\ &\quad - \alpha_{ab}x_a(1 + \alpha_{ab}^2)\Phi'(\alpha_{ab}x_a)], \end{aligned} \quad (33)$$

$$\frac{1}{n_a}\int d^3v\frac{m_a\mathbf{v}}{3T_a}\cdot C_{ab}^{T0}(f_{aM}\mathbf{v}) = -\frac{\alpha_{ab}}{\tau_{ab}(1 + \alpha_{ab}^2)^{1/2}},$$

$$\frac{1}{n_a}\int d^3v\frac{2}{3}x_a^2C_{ab}^{T0}(f_{aM}x_a^2) = -\frac{2\alpha_{ab}}{\tau_{ab}(1 + \alpha_{ab}^2)^{3/2}},$$

and  $\alpha_{ab} \equiv v_{Ta}/v_{Tb}$ .

In the case of  $m_a \gg m_b$ , which corresponds to  $\alpha_{ab} \ll 1$ , we have  $\theta_{ab} \approx (T_a/T_b)^{1/2}$ ,  $v_D^{ab} \approx v_{\parallel}^{ab} \approx \alpha_{ab}\tau_{ab}^{-1}x_a^{-2}$ ,  $C_{ab}^{T0}(f_{aM}\mathbf{v}) \approx -\alpha_{ab}\tau_{ab}^{-1}f_{aM}\mathbf{v}$ , and  $C_{ab}^{T0}(f_{aM}x_a^2) \approx -2\alpha_{ab}\tau_{ab}^{-1}f_{aM}(x_a^2 - 3/2)$ . Then, Eq. (31) reduces to

$$\begin{aligned} C_{ab}^T(\delta f_a) &= \frac{1}{\tau_{ba}n_a m_a}\left[\frac{T_b}{m_a}\frac{\partial}{\partial \mathbf{v}}\cdot\left\{f_{aM}\frac{\partial}{\partial \mathbf{v}}\left(\frac{\delta f_a}{f_{aM}}\right)\right\}\right. \\ &\quad \left.- f_{aM}\left(1 - \frac{T_b}{T_a}\right)\left\{\frac{m_a}{T_a}\mathbf{u}_a[\delta f_a]\cdot\mathbf{v}\right.\right. \\ &\quad \left.\left.+ 2\frac{\delta T_a[f_a]}{T_a}\left(x_a^2 - \frac{3}{2}\right)\right\}\right] \quad (\text{for } m_a \gg m_b), \end{aligned} \quad (34)$$

which coincides with Eq. (20) for the case of ion-electron collisions. In the opposite case of  $m_a \ll m_b$  (or  $\alpha_{ab} \gg 1$ ), we have  $\theta_{ab} \approx 1$  and  $v_D^{ab} \gg v_{\parallel}^{ab}$ . Then, Eq. (26) is approximated by  $C_{ab}^T(\delta f_a) \approx v_D^{ab}\mathcal{L}\delta f_a$ , which agrees with Eq. (13) for the case of electron-ion collisions. Thus, the test-particle operator given by Eq. (26) or Eq. (31) smoothly covers both ranges of the mass ratio,  $m_a/m_b \gg 1$  and  $m_a/m_b \ll 1$ .

Now that the self-adjoint test-particle collision operator has been obtained as shown in Eq. (26) or Eq. (31), we proceed to construct the model field-particle collision operator  $C_{ab}^F$  such that the conservation laws in Eqs. (5)–(7) and the adjointness relations in Eq. (9) are satisfied. The resulting expression for  $C_{ab}^F$  is given by

$$\begin{aligned} C_{ab}^F(\delta f_b) &= -\mathbf{V}_{ab}[\delta f_b]\cdot C_{ab}^T(f_{aM}m_a\mathbf{v}/T_a) \\ &\quad - W_{ab}[\delta f_b]C_{ab}^T(f_{aM}x_a^2), \end{aligned} \quad (35)$$

respectively, where

$$\begin{aligned} C_{ab}^T(f_{aM}m_a\mathbf{v}/T_a) &= -\theta_{ab}(1 + \alpha_{ab}^2)\frac{f_{aM}m_a\mathbf{v}}{\tau_{ab}T_a} \\ &\quad \times \left[ \frac{3\sqrt{\pi}}{4}\frac{2G(\alpha_{ab}x_a)}{x_a} + \frac{\alpha_{ab}(\theta_{ab} - 1)}{(1 + \alpha_{ab}^2)^{3/2}} \right], \end{aligned} \quad (36)$$

$$\begin{aligned} C_{ab}^T(f_{aM}x_a^2) &= -\theta_{ab}\frac{f_{aM}}{\tau_{ab}}\left[ \frac{3\sqrt{\pi}}{4}\frac{2}{\alpha_{ab}^2x_a} \right. \\ &\quad \times \{\Phi(\alpha_{ab}x_a) - \alpha_{ab}x_a\Phi'(\alpha_{ab}x_a)(1 + \alpha_{ab}^2)\} \\ &\quad \left. + \frac{2\alpha_{ab}(\theta_{ab} - 1)}{(1 + \alpha_{ab}^2)^{3/2}}\left(x_a^2 - \frac{3}{2}\right) \right], \end{aligned} \quad (37)$$

$$\mathbf{V}_{ab}[\delta f_b] \equiv \frac{T_b}{\gamma_{ab}}\int d^3v\frac{\delta f_b}{f_{bM}}C_{ba}^T(f_{bM}m_b\mathbf{v}/T_b), \quad (38)$$

and

$$W_{ab}[\delta f_b] \equiv \frac{T_b}{\eta_{ab}}\int d^3v\frac{\delta f_b}{f_{bM}}C_{ba}^T(f_{bM}x_b^2). \quad (39)$$

In Eqs. (38) and (39),

$$\begin{aligned} \gamma_{ab} &\equiv T_a\int d^3v(m_a v_{\parallel}/T_a)C_{ab}^T(f_{aM}m_a v_{\parallel}/T_a) \\ &= -\frac{n_a m_a}{\tau_{ab}}\frac{\alpha_{ab}}{(1 + \alpha_{ab}^2)^{3/2}}\left(\frac{T_a}{T_b} + \alpha_{ab}^2\right) \\ &= -\frac{16\sqrt{\pi}n_a n_b e_a^2 e_b^2 \ln \Lambda}{3(v_{Ta}^2 + v_{Tb}^2)^{3/2}}\left(\frac{1}{m_a} + \frac{1}{m_b}\right) \end{aligned} \quad (40)$$

and

$$\begin{aligned} \eta_{ab} &\equiv T_a\int d^3v x_a^2 C_{ab}^T(f_{aM}x_a^2) \\ &= -\frac{n_a T_a}{\tau_{ab}}\frac{3\alpha_{ab}}{(1 + \alpha_{ab}^2)^{5/2}}\left(\frac{T_a}{T_b} + \alpha_{ab}^2\right) \\ &= -8\sqrt{\pi}\ln \Lambda\frac{n_a n_b e_a^2 e_b^2 v_{Ta}^2 v_{Tb}^2}{(v_{Ta}^2 + v_{Tb}^2)^{5/2}}\left(\frac{1}{m_a} + \frac{1}{m_b}\right) \end{aligned} \quad (41)$$

are used. We see  $\gamma_{ab} = \gamma_{ba}$  and  $\eta_{ab} = \eta_{ba}$  from Eqs. (40) and (41), respectively.

It can be easily verified that the test-particle operator  $C_{ab}^T$  and the field-particle  $C_{ab}^F$  defined in Eqs. (26) and (35) obey conservation laws for particles, momentum, and energy written in Eqs. (5)–(7). In addition, as shown in Appendix A,  $C_{ab}^T$  and  $C_{ab}^F$  satisfy the adjointness relations and the H-theorem given in Eqs. (9)–(11). We find in Appendix A that the model linearized collision operator  $C_{ab}^L(\delta f_a, \delta f_b) = C_{ab}^T(\delta f_a) + C_{ab}^L(\delta f_b)$  vanishes if and only if  $\delta f_a$  and  $\delta f_b$  take the perturbed Maxwellian form in Eq. (11) with  $\mathbf{u}_a = \mathbf{u}_b$  and  $\delta T_a/T_a = \delta T_b/T_b$ .

For the case of  $(a, b) = (e, i)$ , the model collision operators given in Eqs. (26) and (35) coincide with the corresponding electron-ion collision operators in Eq. (13) to the lowest order in  $(m_e/m_i)^{1/2}$ , although the former operators also contain higher-order terms such as the electron energy diffusion term. For  $(a, b) = (i, e)$ , the test-particle operator in Eq. (26) reduces to Eq. (20) as mentioned previously.

When  $T_a = T_b$ , Eq. (26) represents the exact Landau test-particle collision operator. Especially, for collisions between particles of the same species ( $a = b$ ), the combination of Eqs. (26) and (35) gives the same linearized model collision operator given in Refs. 7–9.

## V. COLLISION OPERATORS FOR GYROKINETIC EQUATIONS

In this section, for the purpose of application to the gyrokinetic equation, we derive the gyrophase-averaged form of the linearized model collision operator presented in the previous section. In the gyrokinetic theory, fluctuations with short wavelengths in the directions perpendicular to the magnetic field  $\mathbf{B}$  are treated. The perturbed particle distribution function is represented by  $\delta f_a = \sum_{\mathbf{k}_\perp} \delta f_{a\mathbf{k}_\perp} \exp[iS_{\mathbf{k}_\perp}(\mathbf{x})]$ , where the eikonal  $S_{\mathbf{k}_\perp}$  describes the rapid perpendicular variation and its gradient gives the perpendicular wavenumber vector  $\mathbf{k}_\perp = \nabla S_{\mathbf{k}_\perp}$ .<sup>24</sup> We should note that the amplitude  $\delta f_{a\mathbf{k}_\perp}$  for the wavenumber vector  $\mathbf{k}_\perp$  still has a slow dependence on the particle position  $\mathbf{x}$  and it is divided into the adiabatic and nonadiabatic parts as

$$\delta f_{a\mathbf{k}_\perp} = -\frac{e_a \phi_{\mathbf{k}_\perp}}{T_a} f_{aM} + h_{a\mathbf{k}_\perp} e^{-ik_\perp \cdot \rho_a}. \quad (42)$$

Here,  $h_{a\mathbf{k}_\perp}$  represents the nonadiabatic part of the distribution function, which is independent of the gyrophase, and the gyroradius vector  $\rho_a \equiv \mathbf{b} \times \mathbf{v} / \Omega_a$  contains the gyrophase dependence, where  $\mathbf{b} \equiv \mathbf{B}$  and  $\Omega_a \equiv e_a B / m_a c$  denote the unit vector parallel to the magnetic field and the gyrofrequency, respectively. The gyrophase  $\varphi$  is defined by the angle of the direction of the perpendicular velocity  $\mathbf{v}_\perp$  (or the gyroradius vector  $\rho_a$ ) around the magnetic field line. Using the gyrokinetic ordering in terms of the small parameter  $\rho_a / L$  where  $L$  is a gradient scale length of a macroscopic variable such as the equilibrium pressure, the gyrokinetic equation<sup>5</sup> for  $h_{a\mathbf{k}_\perp}$  is derived from the Boltzmann equation as

$$\begin{aligned} & \left[ \frac{\partial}{\partial t} + v_\parallel \mathbf{b} \cdot \nabla + i(\omega_E + \omega_{Da}) \right] h_{a\mathbf{k}_\perp} \\ &= \frac{e_a f_{aM}}{T_a} \left[ \frac{\partial}{\partial t} + i(\omega_E + \omega_{*a}^T) \right] \psi_{a\mathbf{k}_\perp} \\ &+ \frac{c}{B} \sum_{\mathbf{k}'_\perp + \mathbf{k}''_\perp = \mathbf{k}_\perp} [\mathbf{b} \cdot (\mathbf{k}'_\perp \times \mathbf{k}''_\perp)] \psi_{a\mathbf{k}'_\perp} h_{a\mathbf{k}''_\perp} + \sum_b C_{ab}^{(GK)}, \end{aligned} \quad (43)$$

where  $\omega_E \equiv \mathbf{k}_\perp \cdot (c\mathbf{E} \times \mathbf{b} / B)$ ,  $\omega_{Da} \equiv \mathbf{k}_\perp \cdot (c\mathbf{b} / e_a B) \times (\mu \nabla B + m_a v_\parallel^2 \mathbf{b} \cdot \nabla \mathbf{b})$ ,  $\omega_{*a}^T \equiv \omega_{*a} [1 + \eta_a (x_a^2 - 3/2)]$ ,  $\omega_{*a} \equiv \mathbf{k}_\perp \cdot (cT_a \mathbf{b} / e_a B) \times \nabla \ln n_a$ , and  $\eta_a \equiv d \ln T_a / d \ln n_a$ . Here,  $h_{a\mathbf{k}_\perp}$  is regarded as a function of time  $t$  and phase-space variables  $\mathbf{x}$ ,  $w \equiv m_a v^2 / 2$ , and  $\mu \equiv m_a v_\perp^2 / 2B$ . The gyrophase-averaged potential  $\psi_{a\mathbf{k}_\perp}$  for the turbulent electromagnetic fields is defined in terms of the electrostatic potential  $\phi_{\mathbf{k}_\perp}$  and the vector potential  $\mathbf{A}_{\mathbf{k}_\perp}$  by

$$\begin{aligned} \psi_{a\mathbf{k}_\perp} &\equiv \oint \frac{d\varphi}{2\pi} e^{ik_\perp \cdot \rho_a} \left( \phi_{\mathbf{k}_\perp} - \frac{\mathbf{v}}{c} \cdot \mathbf{A}_{\mathbf{k}_\perp} \right) \\ &= J_0 \left( \frac{k_\perp v_\perp}{\Omega_a} \right) \left( \phi_{\mathbf{k}_\perp} - \frac{v_\parallel}{c} A_{\parallel \mathbf{k}_\perp} \right) + J_1 \left( \frac{k_\perp v_\perp}{\Omega_a} \right) \frac{v_\perp}{c} \frac{B_{\parallel \mathbf{k}_\perp}}{k_\perp}, \end{aligned} \quad (44)$$

where  $A_{\parallel \mathbf{k}_\perp} \equiv \mathbf{b} \cdot \mathbf{A}_{\mathbf{k}_\perp}$  and  $B_{\parallel \mathbf{k}_\perp} \equiv i\mathbf{b} \cdot (\mathbf{k}_\perp \times \mathbf{A}_{\mathbf{k}_\perp})$ . The gyrokinetic collision term  $C_{ab}^{(GK)}$  is defined by taking the gyrophase average of the linearized collision term as<sup>7,25,26</sup>

$$C_{ab}^{(GK)} \equiv \oint \frac{d\varphi}{2\pi} e^{ik_\perp \cdot \rho_a} C_{ab}^L(\delta f_{a\mathbf{k}_\perp}, \delta f_{b\mathbf{k}_\perp}). \quad (45)$$

Since the gyrokinetic equation shown in Eq. (43) describes the fluctuation part with the perpendicular wavenumber vector  $\mathbf{k}_\perp$ , the equilibrium part of the collision term  $C_{ab}(f_{aM}, f_{bM})$  ( $\neq 0$  for  $T_a \neq T_b$ ) does not appear in Eq. (45).

Using Eqs. (31) and (35),  $C_{ab}^{(GK)}$  is written as the sum of the test- and field-particle collision parts,

$$C_{ab}^{(GK)} = C_{ab}^{T(GK)} + C_{ab}^{F(GK)}. \quad (46)$$

The test-particle part is given by

$$\begin{aligned} C_{ab}^{T(GK)} &= \oint \frac{d\varphi}{2\pi} e^{ik_\perp \cdot \rho_a} C_{ab}^T(e^{-ik_\perp \cdot \rho_a} h_{a\mathbf{k}_\perp}) \\ &= \oint \frac{d\varphi}{2\pi} e^{ik_\perp \cdot \rho_a} C_{ab}^{T0}(e^{-ik_\perp \cdot \rho_a} h_{a\mathbf{k}_\perp}) \\ &+ (\theta_{ab} - 1) \oint \frac{d\varphi}{2\pi} e^{ik_\perp \cdot \rho_a} \mathcal{P}_a C_{ab}^{T0}(e^{-ik_\perp \cdot \rho_a} h_{a\mathbf{k}_\perp}) \\ &+ (\theta_{ab} - 1) \oint \frac{d\varphi}{2\pi} e^{ik_\perp \cdot \rho_a} C_{ab}^{T0} \mathcal{P}_a(e^{-ik_\perp \cdot \rho_a} h_{a\mathbf{k}_\perp}) \\ &+ (\theta_{ab} - 1)^2 \oint \frac{d\varphi}{2\pi} e^{ik_\perp \cdot \rho_a} \mathcal{P}_a C_{ab}^{T0} \mathcal{P}_a(e^{-ik_\perp \cdot \rho_a} h_{a\mathbf{k}_\perp}), \end{aligned} \quad (47)$$

where the first term on the right-hand side is given by

$$\begin{aligned} & \oint \frac{d\varphi}{2\pi} e^{ik_\perp \cdot \rho_a} C_{ab}^{T0}(e^{-ik_\perp \cdot \rho_a} h_{a\mathbf{k}_\perp}) \\ &= \nu_D^{ab}(v) \mathcal{L} h_{a\mathbf{k}_\perp} + \frac{1}{v^2} \frac{\partial}{\partial v} \left[ \frac{\nu_\parallel^{ab}(v)}{2} v^4 f_{aM} \frac{\partial}{\partial v} \left( \frac{h_{a\mathbf{k}_\perp}}{f_{aM}} \right) \right] \\ &- h_{a\mathbf{k}_\perp} \frac{k_\perp^2}{4\Omega_a} [\nu_D^{ab}(v)(2v_\parallel^2 + v_\perp^2) + \nu_\parallel^{ab}(v)v_\perp^2]. \end{aligned} \quad (48)$$

The other terms on the right-hand side of Eq. (47) are rewritten by using

$$\begin{aligned} & \oint \frac{d\varphi}{2\pi} e^{ik_\perp \cdot \rho_a} \mathcal{P}_a C_{ab}^{T0}(e^{-ik_\perp \cdot \rho_a} h_{a\mathbf{k}_\perp}) \\ &= \frac{f_{aM}}{n_a} \left[ J_0 v_\parallel \int d^3 v J_0 \frac{h_{a\mathbf{k}_\perp}}{f_{aM}} C_{ab}^{T0}(f_{aM} m_a v_\parallel / T_a) \right. \\ &+ J_1 v_\perp \int d^3 v J_1 \frac{h_{a\mathbf{k}_\perp} v_\perp}{f_{aM} v_\parallel} C_{ab}^{T0}(f_{aM} m_a v_\parallel / T_a) \\ &+ J_0 \left( x_a^2 - \frac{3}{2} \right) \int d^3 v J_0 \frac{h_{a\mathbf{k}_\perp} 2}{f_{aM} 3} C_{ab}^{T0}(f_{aM} x_a^2) \left. \right], \end{aligned} \quad (49)$$



$$\begin{aligned}
 & \oint \frac{d\varphi}{2\pi} e^{i\mathbf{k}_\perp \cdot \boldsymbol{\rho}_a} C_{ab}^{T0} \mathcal{P}_a(e^{-i\mathbf{k}_\perp \cdot \boldsymbol{\rho}_a} h_{a\mathbf{k}_\perp}) \\
 &= J_0 C_{ab}^{T0} (f_{aM} m_a v_{\parallel} / T_a) n_a^{-1} \int d^3v J_0 h_{a\mathbf{k}_\perp} v_{\parallel} \\
 &+ J_1 \frac{v_\perp}{v_{\parallel}} C_{ab}^{T0} (f_{aM} m_a v_{\parallel} / T_a) n_a^{-1} \int d^3v J_1 h_{a\mathbf{k}_\perp} v_\perp \\
 &+ J_0 C_{ab}^{T0} (f_{aM} x_a^2) n_a^{-1} \int d^3v J_0 h_{a\mathbf{k}_\perp} \frac{2}{3} \left( x_a^2 - \frac{3}{2} \right), \quad (50)
 \end{aligned}$$

and

$$\begin{aligned}
 & \oint \frac{d\varphi}{2\pi} e^{i\mathbf{k}_\perp \cdot \boldsymbol{\rho}_a} C_{ab}^{T0} \mathcal{P}_a(e^{-i\mathbf{k}_\perp \cdot \boldsymbol{\rho}_a} h_{a\mathbf{k}_\perp}) \\
 &= -\frac{f_{aM}}{n_a \tau_{ab}} \frac{\alpha_{ab}}{(1 + \alpha_{ab}^2)^{1/2}} \left[ \frac{m_a}{T_a} \left( J_0 v_{\parallel} \int d^3v J_0 h_{a\mathbf{k}_\perp} v_{\parallel} \right. \right. \\
 &+ \left. \left. J_1 v_\perp \int d^3v J_1 h_{a\mathbf{k}_\perp} v_\perp \right) + \frac{2J_0}{1 + \alpha_{ab}^2} \left( x_a^2 - \frac{3}{2} \right) \right. \\
 &\left. \times \int d^3v J_0 h_{a\mathbf{k}_\perp} \frac{2}{3} \left( x_a^2 - \frac{3}{2} \right) \right], \quad (51)
 \end{aligned}$$

where  $C_{ab}^{T0}(f_{aM} m_a v_{\parallel} / T_a)$  and  $C_{ab}^{T0}(f_{aM} x_a^2)$  are evaluated from Eq. (33) and the Bessel functions  $J_0 = J_0(k_\perp v_\perp / \Omega_a)$  and  $J_1 = J_1(k_\perp v_\perp / \Omega_a)$  are used. The field-particle part of the gyrokinetic collision operator is given by

$$\begin{aligned}
 C_{ab}^{F(GK)} &= \oint \frac{d\varphi}{2\pi} e^{i\mathbf{k}_\perp \cdot \boldsymbol{\rho}_a} C_{ab}^F(e^{-i\mathbf{k}_\perp \cdot \boldsymbol{\rho}_a} h_{b\mathbf{k}_\perp}) \\
 &= -\frac{T_b}{\gamma_{ab}} C_{ab}^T(f_{aM} m_a v_{\parallel} / T_a) \left[ J_0 \int d^3v J_0 \frac{h_{b\mathbf{k}_\perp}}{f_{bM}} \right. \\
 &\times C_{ba}^T(f_{bM} m_b v_{\parallel} / T_b) + J_1 \frac{v_\perp}{v_{\parallel}} \int d^3v J_1 \frac{h_{b\mathbf{k}_\perp}}{f_{bM}} \\
 &\times \left. \frac{v_\perp}{v_{\parallel}} C_{ba}^T(f_{bM} m_b v_{\parallel} / T_b) \right] - \frac{T_b}{\eta_{ab}} J_0 C_{ab}^T(f_{aM} x_a^2) \\
 &\times \int d^3v J_0 \frac{h_{b\mathbf{k}_\perp}}{f_{bM}} C_{ba}^T(f_{bM} x_b^2), \quad (52)
 \end{aligned}$$

where  $C_{ab}^T(f_{aM} m_a v_{\parallel} / T_a)$  and  $C_{ab}^T(f_{aM} x_a^2)$  on the right-hand side are evaluated by using Eqs. (36) and (37).

## VI. ENTROPY BALANCES IN GYROKINETIC ELECTROMAGNETIC TURBULENCE

We now derive several relations among the entropy variable associated with the turbulent distribution functions, the energy of electromagnetic fluctuations, the turbulent particle and heat transport, and the collisional dissipation in gyrokinetic turbulence. Here, the H-theorem shown in Eq. (10) guarantees the positive collisional dissipation which balances with the finite turbulent transport driven by the thermodynamic gradient forces in the steady turbulent state.

The difference  $\delta S_a \equiv S_{aM} - \langle S_a \rangle_{\text{ensemble}}$  between the macroscopic entropy density  $S_{aM} \equiv -\int d^3v f_{aM} \log f_{aM}$  and the

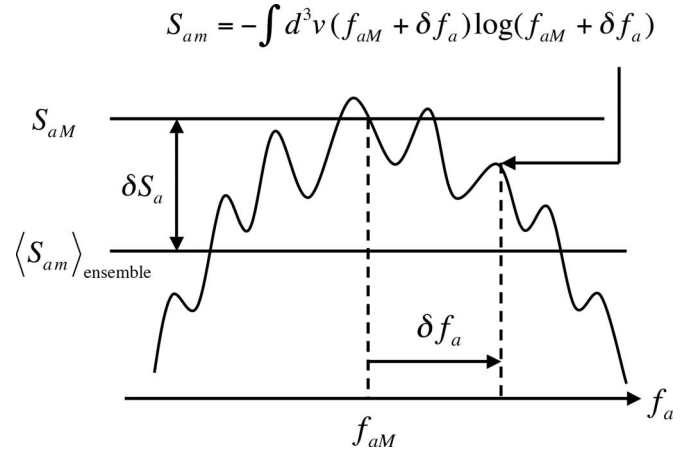

FIG. 1. The relation among the entropy variables  $S_{aM}$ ,  $\langle S_a \rangle_{\text{ensemble}}$ , and  $\delta S_a$ . The abscissa represents the ensemble (or the functional space) of  $f_a \equiv f_{aM} + \delta f_a$ . The microscopic entropy density  $S_{am} \equiv -\int d^3v (f_{aM} + \delta f_a) \log(f_{aM} + \delta f_a)$  is delineated by a curved line.

ensemble-averaged (or statistically averaged) microscopic entropy density  $\langle S_{am} \rangle_{\text{ensemble}} \equiv -\langle \int d^3v (f_{aM} + \delta f_a) \log(f_{aM} + \delta f_a) \rangle_{\text{ensemble}}$  is given by<sup>27</sup>

$$\delta S_a = \sum_{\mathbf{k}_\perp} \left\langle \int d^3v \frac{|\delta f_{a\mathbf{k}_\perp}|^2}{2f_{aM}} \right\rangle_{\text{ensemble}}, \quad (53)$$

where terms of higher order than  $\mathcal{O}(\delta f_a^2)$  are neglected. As seen from Eq. (53), our definition of  $\delta S_a \equiv S_{aM} - \langle S_a \rangle_{\text{ensemble}}$  is such that  $\delta S_a$  never becomes negative. The relation among  $S_{aM}$ ,  $\langle S_a \rangle_{\text{ensemble}}$ , and  $\delta S_a$  is schematically shown in Fig. 1, where the abscissa and ordinate represent the ensemble (or the functional space) of  $f_a \equiv f_{aM} + \delta f_a$  and the entropy density, respectively. The average value  $\langle S_a \rangle_{\text{ensemble}}$  of the microscopic entropy density never exceeds the entropy density  $S_{aM}$  in the equilibrium state.

Using Eq. (42), the contribution from the turbulent fluctuation with the wave number vector  $\mathbf{k}_\perp$  to  $\delta S_a$  is written as

$$\begin{aligned}
 \int d^3v \frac{|\delta f_{a\mathbf{k}_\perp}|^2}{2f_{aM}} &= \int d^3v \frac{|h_{a\mathbf{k}_\perp}|^2}{2f_{aM}} - \frac{n_a e_a^2}{2T_a^2} |\phi_{\mathbf{k}_\perp}|^2 \\
 &- \frac{e_a}{T_a} \text{Re}[\phi_{\mathbf{k}_\perp}^* \delta n_{a\mathbf{k}_\perp}], \quad (54)
 \end{aligned}$$

where  $\text{Re}[\dots]$  and  $(\dots)^*$  represent the real part and the complex conjugate, respectively, and the perturbed density  $\delta n_a$  is defined by  $\delta n_a \equiv \int d^3v \delta f_a$ . We find from Eq. (54) that the turbulent entropy variable is given by  $\int d^3v |\delta f_{a\mathbf{k}_\perp}|^2 / 2f_{aM} = (n_a e_a^2 / 2T_a^2) |\phi_{\mathbf{k}_\perp}|^2$  in the case of the completely adiabatic response, for which  $h_{a\mathbf{k}_\perp} = 0$  and  $\delta n_{a\mathbf{k}_\perp} = n_a e_a \phi_{\mathbf{k}_\perp} / T_a$ . This expression of the squared electrostatic potential is often seen for electrons in the studies of the ion temperature gradient (ITG) mode<sup>28</sup> where adiabatic electrons are assumed. Besides, as shown in Appendix B, Eq. (54) can be given in another form to show separately the contribution from the polarization part of the distribution function. Using Eq. (42) and noting that  $h_{a\mathbf{k}_\perp}$  is independent of the gyrophase, we obtain

$$\int d^3v \frac{|\delta f_{ak_\perp}|^2}{2f_{aM}} v_{\parallel} = -\frac{n_a e_a}{T_a} \text{Re}(\phi_{\mathbf{k}_\perp}^* u_{\parallel a \mathbf{k}_\perp}) + \int d^3v \frac{|h_{ak_\perp}|^2}{2f_{aM}} v_{\parallel}, \quad (55)$$

$$\int d^3v \frac{|\delta f_{ak_\perp}|^2}{2f_{aM}} \mathbf{v}_\perp = -\frac{n_a e_a}{T_a} \text{Re}(\phi_{\mathbf{k}_\perp}^* \mathbf{u}_{\perp a \mathbf{k}_\perp}),$$

which are related to the turbulent transport of  $\delta S_a$ . Here, the perpendicular flow velocity  $\mathbf{u}_{\perp a \mathbf{k}_\perp}$  is defined by

$$\begin{aligned} \mathbf{u}_{\perp a \mathbf{k}_\perp} &\equiv n_a^{-1} \int d^3v \delta f_{ak_\perp} \mathbf{v}_\perp \\ &= -i(\mathbf{k}_\perp \times \mathbf{b}/k_\perp) n_a^{-1} \int d^3v J_1(k_\perp v_\perp / \Omega_a) h_{ak_\perp} v_\perp. \end{aligned}$$

Hereafter, we consider turbulence in magnetically confined plasmas, in which equilibrium magnetic field lines form toroidal nested surfaces. We also neglect the temporal variation of the equilibrium density  $n_a$  and temperature  $T_a$  (or the equilibrium distribution function  $f_{aM}$ ) as higher-order terms with respect to the gyroradius parameter while we still keep the time derivative terms of the ensemble average of squared fluctuations such as  $(\partial/\partial t) \langle \int d^3v |h_{ak_\perp}|^2 / 2f_{aM} \rangle_{\text{ensemble}}$  in the several forms of entropy balance equations shown below, which are useful for monitoring the accuracy of gyrokinetic turbulence simulations. Now, from the gyrokinetic equation shown in Eq. (43), we obtain<sup>18</sup>

$$\begin{aligned} &\frac{\partial}{\partial t} \sum_{\mathbf{k}_\perp} \left\langle \left\langle \int d^3v \frac{|h_{ak_\perp}|^2}{2f_{aM}} \right\rangle \right\rangle \\ &= J_{a1}^A X_{a1}^A + J_{a2}^A X_{a2}^A + J_{a3}^A X_{a3}^A \\ &\quad + \sum_{\mathbf{k}_\perp} \text{Re} \left\langle \left\langle \int d^3v \frac{\delta f_{ak_\perp}^*}{f_{aM}} \sum_b C_{ab}^L(\delta f_{ak_\perp}, \delta f_{bk_\perp}) \right\rangle \right\rangle, \end{aligned} \quad (56)$$

where  $\langle\langle \dots \rangle\rangle$  represents a double average over the magnetic flux surface and the ensemble. Here, the thermodynamic gradient forces

$$[X_{a1}^A, X_{a2}^A] \equiv \left[ -\frac{\partial \ln p_a}{\partial s} - \frac{e_a}{T_a} \frac{\partial \Phi}{\partial s}, -\frac{\partial \ln T_a}{\partial s} \right] \quad (57)$$

make conjugate pairs with  $J_{a1}^A$  and  $J_{a2}^A$  which represent the surface-averaged radial fluxes of particles and heat defined by<sup>18</sup>

$$\begin{aligned} [J_{a1}^A, J_{a2}^A] &\equiv \left[ \Gamma_a^A, \frac{q_a^A}{T_a} \right] \\ &\equiv \text{Re} \left\langle \left\langle \int d^3v \left[ 1, \left( x^2 - \frac{5}{2} \right) \right] \right. \right. \\ &\quad \left. \left. \times \sum_{\mathbf{k}_\perp} h_{ak_\perp}^* \left( -i \frac{c}{B} \psi_{ak_\perp} \mathbf{k}_\perp \times \mathbf{b} \right) \cdot \nabla s \right\rangle \right\rangle, \end{aligned} \quad (58)$$

where  $s$  denotes an arbitrary radial coordinate to label flux surfaces and the gyrophase-averaged electromagnetic potential  $\psi_{ak_\perp}$  is defined by Eq. (44). Appendix C shows the gy-

rokinetic Maxwell equations which govern the turbulent electromagnetic fields. Combining Eqs. (C4) and (C5) in Appendix C and the definition in Eq. (58), we find that the turbulent radial particle fluxes  $J_{a1}^A$  satisfy the ambipolarity condition,

$$\sum_a e_a J_{a1}^A = 0. \quad (59)$$

In Eq. (56),  $X_{a3}^A \equiv 1/T_a$  is the inverse temperature while  $J_{a3}^A$  is related to the turbulent heat exchange and written as

$$\begin{aligned} J_{a3}^A &\equiv e_a \sum_{\mathbf{k}_\perp} \text{Re} \left\langle \left\langle \int d^3v h_{ak_\perp}^* \frac{\partial \psi_{ak_\perp}}{\partial t} \right\rangle \right\rangle \\ &= -\frac{\partial}{\partial t} \left[ T_a \sum_{\mathbf{k}_\perp} \left\langle \left\langle \int d^3v \frac{|\delta f_{ak_\perp}|^2 - |h_{ak_\perp}|^2}{2f_{aM}} \right\rangle \right\rangle \right] \\ &\quad - \sum_{\mathbf{k}_\perp} \left\langle \left\langle \nabla \cdot \left[ T_a \int d^3v \frac{|\delta f_{ak_\perp}|^2}{2f_{aM}} \mathbf{v} \right] \right\rangle \right\rangle \\ &\quad + e_a n_a \sum_{\mathbf{k}_\perp} \text{Re} \langle\langle (\mathbf{u}_{ak_\perp}^* \cdot \mathbf{E}_{\mathbf{k}_\perp})^{(3)} \rangle\rangle, \end{aligned} \quad (60)$$

where the detailed expression to define  $(\mathbf{u}_{ak_\perp}^* \cdot \mathbf{E}_{\mathbf{k}_\perp})^{(3)}$  is given by Eq. (C8) in Appendix C.

Equation (56) gives one of the entropy balance equations. Its left-hand side represents the variation rate of the nonadiabatic part of the turbulent entropy density while the right-hand side consists of the source part in the inner-product form  $\mathbf{J} \cdot \mathbf{X}$  and the sink part due to the collisional dissipation. Using Eq. (60), Eq. (56) is rewritten in another form of the turbulent entropy balance equation,

$$\begin{aligned} &\frac{\partial}{\partial t} \sum_{\mathbf{k}_\perp} \left\langle \left\langle \int d^3v \frac{|\delta f_{ak_\perp}|^2}{2f_{aM}} \right\rangle \right\rangle + \sum_{\mathbf{k}_\perp} \left\langle \left\langle \nabla \cdot \left[ \int d^3v \frac{|\delta f_{ak_\perp}|^2}{2f_{aM}} \mathbf{v} \right] \right\rangle \right\rangle \\ &\quad - \sum_{\mathbf{k}_\perp} \text{Re} \left\langle \left\langle \int d^3v \frac{\delta f_{ak_\perp}^*}{f_{aM}} \sum_b C_{ab}^L(\delta f_{ak_\perp}, \delta f_{bk_\perp}) \right\rangle \right\rangle \\ &= J_{a1}^A X_{a1}^A + J_{a2}^{\text{anom}} X_{a2}^A + \frac{e_a n_a}{T_a} \sum_{\mathbf{k}_\perp} \text{Re} \langle\langle (\mathbf{u}_{ak_\perp}^* \cdot \mathbf{E}_{\mathbf{k}_\perp})^{(3)} \rangle\rangle, \end{aligned} \quad (61)$$

where  $J_{a2}^{\text{anom}} \equiv q_a^{\text{anom}}/T_a$  is given from  $J_{a2}^A$  by the relation<sup>18</sup>

$$J_{a2}^{\text{anom}} \equiv \frac{q_a^{\text{anom}}}{T_a} = J_{a2}^A + \sum_{\mathbf{k}_\perp} \left\langle \left\langle \int d^3v \frac{|\delta f_{ak_\perp}|^2}{2f_{aM}} \mathbf{v} \cdot \nabla s \right\rangle \right\rangle. \quad (62)$$

Using Eqs. (C10) and (62), we find

$$\sum_a T_a J_{a2}^A = \sum_a T_a J_{a2}^{\text{anom}} + \sum_{\mathbf{k}_\perp} \frac{c}{4\pi} \text{Re} \langle\langle (\mathbf{E}_{\mathbf{k}_\perp}^* \times \mathbf{B}_{\mathbf{k}_\perp}) \cdot \nabla s \rangle\rangle, \quad (63)$$

which shows that  $\sum_a T_a J_{a2}^A$  is equal to the sum of the turbulent heat flux  $\sum_a T_a J_{a2}^{\text{anom}} = \sum_a q_a^{\text{anom}}$  and the Poynting flux due to the turbulent electromagnetic fields. Using Eq. (C9), (C10), and (60), we find

$$\sum_a J_{a3}^A = -\frac{\partial}{\partial t} \sum_{\mathbf{k}_\perp} \left[ T_a \left\langle \left\langle \int d^3v \frac{|\delta f_{a\mathbf{k}_\perp}|^2 - |h_{a\mathbf{k}_\perp}|^2}{2f_{aM}} \right\rangle \right\rangle + \frac{1}{8\pi} \langle \langle |\mathbf{E}_{\mathbf{k}_\perp}|^2 + |\mathbf{B}_{\mathbf{k}_\perp}|^2 \rangle \rangle \right], \quad (64)$$

which implies  $\sum_a J_{a3}^A = 0$  in the steady turbulence state. From Eqs. (C9), (C10), and (61), we obtain

$$\begin{aligned} \frac{\partial}{\partial t} \sum_{\mathbf{k}_\perp} \left[ \sum_a T_a \left\langle \left\langle \int d^3v \frac{|\delta f_{a\mathbf{k}_\perp}|^2}{2f_{aM}} \right\rangle \right\rangle + \frac{1}{8\pi} \langle \langle |\mathbf{E}_{\mathbf{k}_\perp}|^2 + |\mathbf{B}_{\mathbf{k}_\perp}|^2 \rangle \rangle \right] \\ = \sum_a T_a (J_{a1}^A X_{a1}^A + J_{a2}^A X_{a2}^A) \\ + \sum_{\mathbf{k}_\perp} \sum_{a,b} T_a \left\langle \left\langle \int d^3v \frac{\delta f_{a\mathbf{k}_\perp}^*}{f_{aM}} C_{ab}^L(\delta f_{a\mathbf{k}_\perp}, \delta f_{b\mathbf{k}_\perp}) \right\rangle \right\rangle. \end{aligned} \quad (65)$$

The above entropy balance equation can be used to examine the accuracy of gyrokinetic turbulence simulation. On the left-hand side of Eq. (65), the magnitude of the electric field energy term is evaluated as  $k_\perp^2 \lambda_D^2$  ( $\lambda_D$  is the Debye length) times the adiabatic portion included in the first term. Thus, the electric field energy term vanishes in the case of  $k_\perp^2 \lambda_D^2 \ll 1$  where the quasineutrality condition is used instead of Poisson's equation. For the electrostatic turbulence, the magnetic energy term disappears, too. The simplified version of Eq. (65) for the electrostatic toroidal ITG turbulence was used for testing the phase-space resolution in simulation studies in Refs. 29 and 30, where the turbulent ion entropy density was expressed by using Eq. (B3). As pointed out by Krommes and Hu<sup>17</sup> in the discussion of entropy paradox, Eq. (65) implies that, without collisions, the turbulent entropy variable included in the left-hand side of Eq. (65) monotonically increases in the presence of the stationary turbulent transport fluxes  $J_{aj}^A$  combined with the gradient forces  $X_{aj}$  ( $j=1,2$ ). In fact, this was verified in the collisionless slab ITG turbulence simulation,<sup>31,32</sup> where the finite turbulent heat flux was found to continuously generate fine structures in the velocity-space distribution function through the phase-mixing entropy-cascade process that leads to the monotonic increase in the entropy variable. The sum of the turbulent entropy and electromagnetic energy quantities appearing on the left-hand side of Eq. (65) was called the generalized energy by Schekochihin *et al.*<sup>25</sup> who used it to investigate turbulent cascades in astrophysical plasmas.

We now define zonal modes as fluctuations which have the wave number vectors in the direction perpendicular to flux surfaces,  $\mathbf{k}_\perp = k_s \nabla s$ . It is important to note that the zonal modes never contribute to the radial transport fluxes  $J_{a1}^A$  and  $J_{a2}^A$  as seen from Eq. (58). Then, we divide the summation over wave number vectors into regions of zonal and nonzonal modes,

$$\sum_{\mathbf{k}_\perp} = \sum_{\mathbf{k}_\perp(Z)} + \sum_{\mathbf{k}_\perp(NZ)}, \quad (66)$$

where (Z) and (NZ) represent zonal and nonzonal modes, respectively. Now, Eq. (65) is divided into nonzonal and zonal parts as

$$\begin{aligned} \frac{\partial}{\partial t} \sum_{\mathbf{k}_\perp(NZ)} \left[ \sum_a T_a \left\langle \left\langle \int d^3v \frac{|\delta f_{a\mathbf{k}_\perp}|^2}{2f_{aM}} \right\rangle \right\rangle + \frac{1}{8\pi} \langle \langle |\mathbf{E}_{\mathbf{k}_\perp}|^2 + |\mathbf{B}_{\mathbf{k}_\perp}|^2 \rangle \rangle \right] \\ = \sum_a T_a (J_{a1}^A X_{a1}^A + J_{a2}^A X_{a2}^A) - \mathcal{T}(NZ \rightarrow Z) \\ + \sum_{\mathbf{k}_\perp(NZ)} \sum_{a,b} T_a \left\langle \left\langle \int d^3v \frac{\delta f_{a\mathbf{k}_\perp}^*}{f_{aM}} C_{ab}^L(\delta f_{a\mathbf{k}_\perp}, \delta f_{b\mathbf{k}_\perp}) \right\rangle \right\rangle, \end{aligned} \quad (67)$$

and

$$\begin{aligned} \frac{\partial}{\partial t} \sum_{\mathbf{k}_\perp(Z)} \left[ \sum_a T_a \left\langle \left\langle \int d^3v \frac{|\delta f_{a\mathbf{k}_\perp}|^2}{2f_{aM}} \right\rangle \right\rangle + \frac{1}{8\pi} \langle \langle |\mathbf{E}_{\mathbf{k}_\perp}|^2 + |\mathbf{B}_{\mathbf{k}_\perp}|^2 \rangle \rangle \right] \\ = \mathcal{T}(NZ \rightarrow Z) + \sum_{\mathbf{k}_\perp(Z)} \sum_{a,b} T_a \\ \times \left\langle \left\langle \int d^3v \frac{\delta f_{a\mathbf{k}_\perp}^*}{f_{aM}} C_{ab}^L(\delta f_{a\mathbf{k}_\perp}, \delta f_{b\mathbf{k}_\perp}) \right\rangle \right\rangle, \end{aligned} \quad (68)$$

respectively. Equations (67) and (68) are derived in the same way as Eq. (65). Multiplying the gyrokinetic equation, Eq. (43), by  $h_{a\mathbf{k}_\perp}^*/f_{aM}$ , taking its real part, summing it up over wavenumber vectors  $\mathbf{k}_\perp$  for nonzonal (or zonal) modes, and using Eqs. (62), (C9), and (C10) yield Eq. (67) [or Eq. (68)]. We should note that the source terms given by the product of the fluxes  $J_{aj}^A$  and  $X_{aj}^A$  ( $j=1,2$ ) appear in Eq. (67) while they do not in Eq. (68). Here,  $\mathcal{T}(NZ \rightarrow Z)$  is obtained from the nonlinear term in Eq. (43) through the above-mentioned derivation processes and it represents the nonlinear entropy transfer from the nonzonal modes to the zonal modes, which is expressed by

$$\begin{aligned} \mathcal{T}(NZ \rightarrow Z) \\ \equiv \sum_a T_a \left\langle \left\langle \frac{c}{B} \sum_{\mathbf{k}_\perp(Z)} \sum_{\mathbf{k}'_\perp(NZ)} \sum_{\mathbf{k}''_\perp(NZ)} \delta_{\mathbf{k}'_\perp + \mathbf{k}''_\perp, \mathbf{k}} \right. \right. \\ \left. \left. \times [\mathbf{b} \cdot (\mathbf{k}'_\perp \times \mathbf{k}''_\perp)] \int d^3v \frac{1}{f_{aM}} \text{Re}[\psi_{a\mathbf{k}'_\perp} h_{a\mathbf{k}''_\perp} h_{a\mathbf{k}_\perp}^*] \right\rangle \right\rangle. \end{aligned} \quad (69)$$

In the steady turbulence, we find from Eq. (68) that  $\mathcal{T}(NZ \rightarrow Z) > 0$  because of the H-theorem shown in Eq. (10). Thus, we see from Eq. (67) that the zonal modes tend to regulate the amplitudes of the nonzonal modes and the turbulent transport. When zonal flows become unstable to the Kelvin–Helmholtz instability, the free energy (or entropy) can be transferred from the zonal modes to the nonzonal modes.<sup>33</sup> For this case, both of the entropy transfer term  $\mathcal{T}(NZ \rightarrow Z)$  and the collisional dissipation term on the right-hand side of Eq. (68) are negative and the system is not in the steady state but in the transient state where the total squared amplitudes of the zonal modes should decrease temporarily according to Eq. (68).

Balance equations for energylike variables, which are similar to Eqs. (67) and (68), are found in Refs. 34–36 based on fluid models where the product of the Reynolds stress and

the background flow shear plays a role of  $\mathcal{T}(\text{NZ} \rightarrow \text{Z})$  in the turbulence regulation. If a simple approximation  $h_{\mathbf{k}_\perp} \approx (n_{\mathbf{k}_\perp}^{(h)}/n_0)f_{iM}$  is used,  $n_{\mathbf{k}_\perp}^{(h)} = [n_0(e/T_i)\phi_{\mathbf{k}_\perp} + \delta n_e](1 + k_\perp^2 \rho_{ii}^2/2)$  is obtained for small wave numbers  $k_\perp^2 \rho_{ii}^2 \ll 1$  ( $\rho_{ii} \equiv \sqrt{T_i/m_i/\Omega_i}$ ) from the quasineutrality condition in the case of a plasma consisting of electrons and a single species of ions with charge  $e_i = +e$ . The perturbed electron density is approximately given by the Boltzmann relation  $\delta n_e = n_0 e \phi_{\mathbf{k}_\perp} / T_e$  for the electrostatic drift wave turbulence. In the case of cold ions  $T_i \ll T_e$ ,  $\delta n_e$  is neglected in the quasineutrality condition and  $n_{\mathbf{k}_\perp}^{(h)}/n_0 \approx (e/T_i)\phi_{\mathbf{k}_\perp}(1 + k_\perp^2 \rho_{ii}^2/2)$  is used to derive

$$\begin{aligned} \mathcal{T}(\text{NZ} \rightarrow \text{Z}) &\approx \left\langle \left\langle \frac{n_0 m_i c^3}{2B^3} \sum_{\mathbf{k}_\perp(\text{Z})} \sum_{\mathbf{k}'_\perp(\text{NZ})} \sum_{\mathbf{k}''_\perp(\text{NZ})} \delta_{\mathbf{k}'_\perp + \mathbf{k}''_\perp, \mathbf{k}} \right. \right. \\ &\quad \times [\mathbf{b} \cdot (\mathbf{k}'_\perp \times \mathbf{k}''_\perp)] [(k''_\perp)^2 - (k'_\perp)^2] \\ &\quad \times \text{Re}[\phi_{\mathbf{k}'_\perp} \phi_{\mathbf{k}''_\perp} \phi_{\mathbf{k}_\perp}^*] \left. \right\rangle \\ &= \left\langle \left\langle \sum_{\mathbf{k}_\perp(\text{Z})} \sum_{\mathbf{k}'_\perp(\text{NZ})} \sum_{\mathbf{k}''_\perp(\text{NZ})} \delta_{\mathbf{k}'_\perp + \mathbf{k}''_\perp, \mathbf{k}} \right. \right. \\ &\quad \times \text{Re}[\mathbf{v}_{E\mathbf{k}'_\perp} \mathbf{v}_{E\mathbf{k}''_\perp} : (i\mathbf{k}_\perp \mathbf{v}_{E\mathbf{k}_\perp})^*] \left. \right\rangle, \end{aligned} \quad (70)$$

where  $\mathbf{v}_{E\mathbf{k}_\perp} \equiv -i(c/B)\phi_{\mathbf{k}_\perp}(\mathbf{k}_\perp \times \mathbf{b})$  represents the  $\mathbf{E} \times \mathbf{B}$  drift velocity for the wave number vector  $\mathbf{k}_\perp$ . Equation (70) represents the product of the Reynolds stress due to the non-zonal  $\mathbf{E} \times \mathbf{B}$  flows and the zonal  $\mathbf{E} \times \mathbf{B}$  flow shear. Besides, the turbulent entropy density  $\langle \langle \int d^3v |\delta f_{\mathbf{a}\mathbf{k}_\perp}|^2 / (2f_{aM}) \rangle \rangle$  and the collisional dissipation terms in Eqs. (67) and (68) can be represented by the squares of the perturbed fluid variables such as the density, flow, and temperature fluctuations if we use a truncated expression of the distribution function in terms of the velocity-moment expansion as shown in Ref. 37. Thus, the balance equations obtained from fluid models, which represent the interaction between the turbulent (non-zonal) fluctuations and shear (or zonal) flows, can be regarded as an appropriate fluid limit of Eqs. (67) and (68).

The variation of the macroscopic entropy density  $S_{aM} \equiv -\int d^3v f_{aM} \ln f_{aM}$  is determined by the classical, neoclassical, and turbulent transport as shown in Ref. 18, where the variation rate of  $S_{aM}$  due to all transport processes was derived. Here, retaining only the contribution of the turbulent transport, the balance equation for the macroscopic entropy density is written as

$$\begin{aligned} \frac{\partial S_{aM}}{\partial t} &= \frac{\partial}{\partial t} \langle \langle S_{am} + \delta S_a \rangle \rangle \\ &= -\frac{1}{V'} \frac{\partial}{\partial s} \left[ V' \left( \frac{S_{aM}}{n_a} J_{a1}^A + J_{a2}^{\text{anom}} \right) \right] + J_{a1}^A X_{a1}^A + J_{a2}^{\text{anom}} X_{a2}^A \\ &\quad + \frac{e_a n_a}{T_a} \sum_{\mathbf{k}_\perp} \text{Re} \langle \langle (\mathbf{u}_{\mathbf{k}_\perp}^* \cdot \mathbf{E}_{\mathbf{k}_\perp})^{(3)} \rangle \rangle, \end{aligned} \quad (71)$$

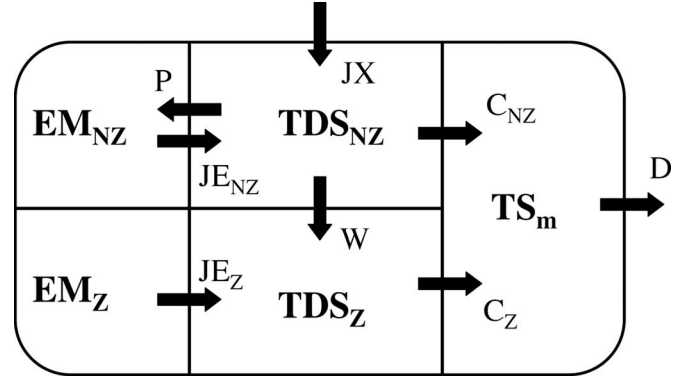

FIG. 2. The diagram representing the entropy balance equations. The entropy and electromagnetic energy quantities are represented by bounded regions while the transfer terms in the entropy balance equations are delineated by arrows. See Table I which shows in detail what quantities the bounded regions and the arrows represent.

where  $V' \equiv dV(s)/ds$  and  $V(s)$  is the volume enclosed by the flux surface with the label  $s$ . Here,  $S_{aM}$  is regarded as a flux-surface function because, to the lowest order,  $n_a$  and  $T_a$  are so, too. The contributions from the classical and neoclassical transport fluxes of particles and heat, which are omitted in Eq. (71), can be found in Ref. 18. Now, based on Eqs. (67), (68), (71), (C9), and (C10), the entropy balances are schematically summarized in Fig. 2, where the entropy and electromagnetic energy quantities are represented by bounded regions and the transfer terms in the entropy balance equations are delineated by arrows. Table I shows in detail what quantities the bounded regions and the arrows in Fig. 2 represent. For example, the arrow W denotes the entropy transfer  $\mathcal{T}(\text{NZ} \rightarrow \text{Z})$  from the nonzonal to zonal modes defined in Eq. (69). A combination of the regions  $\text{TDS}_{\text{NZ}}$ ,  $\text{TDS}_{\text{Z}}$ , and  $\text{TDS}_m$  gives  $\sum_a T_a S_{aM}$ . In the steady state, the entropy production (the arrow JX) due to the transport fluxes under the thermodynamic gradient forces balances with the collisional dissipation ( $C_{\text{NZ}}$  and  $C_{\text{Z}}$ ), which finally equals the loss (D) due to the divergence of the entropy flow. Note that the zonal

TABLE I. Quantities represented by bounded regions and arrows in Fig. 2.

Region	Quantity
$\text{TS}_m$	$-\sum_a T_a \langle \langle \int d^3v (f_{aM} + \delta f_a) \log(f_{aM} + \delta f_a) \rangle \rangle$
$\text{TDS}_{\text{NZ}}$	$\sum_{\mathbf{k}_\perp(\text{NZ})} \sum_a T_a \langle \langle \int d^3v  \delta f_{\mathbf{a}\mathbf{k}_\perp} ^2 / (2f_{aM}) \rangle \rangle$
$\text{TDS}_{\text{Z}}$	$\sum_{\mathbf{k}_\perp(\text{Z})} \sum_a T_a \langle \langle \int d^3v  \delta f_{\mathbf{a}\mathbf{k}_\perp} ^2 / (2f_{aM}) \rangle \rangle$
$\text{EM}_{\text{NZ}}$	$\sum_{\mathbf{k}_\perp(\text{NZ})} \langle \langle  \mathbf{E}_{\mathbf{k}_\perp} ^2 +  \mathbf{B}_{\mathbf{k}_\perp} ^2 \rangle \rangle / 8\pi$
$\text{EM}_{\text{Z}}$	$\sum_{\mathbf{k}_\perp(\text{Z})} \langle \langle  \mathbf{E}_{\mathbf{k}_\perp} ^2 +  \mathbf{B}_{\mathbf{k}_\perp} ^2 \rangle \rangle / 8\pi$
Arrow	Quantity
JX	$\sum_a T_a (J_{a1}^A X_{a1}^A + J_{a2}^A X_{a2}^A)$
W	$\mathcal{T}(\text{NZ} \rightarrow \text{Z})$ [Eq. (69)]
$C_{\text{NZ}}$	$-\sum_{\mathbf{k}_\perp(\text{NZ})} \sum_{a,b} T_a \langle \langle \int d^3v (\delta f_{\mathbf{a}\mathbf{k}_\perp}^e / f_{aM}) C_{ab}^L (\delta f_{\mathbf{a}\mathbf{k}_\perp}, \delta f_{\mathbf{b}\mathbf{k}_\perp}) \rangle \rangle$
$C_{\text{Z}}$	$-\sum_{\mathbf{k}_\perp(\text{Z})} \sum_{a,b} T_a \langle \langle \int d^3v (\delta f_{\mathbf{a}\mathbf{k}_\perp}^e / f_{aM}) C_{ab}^L (\delta f_{\mathbf{a}\mathbf{k}_\perp}, \delta f_{\mathbf{b}\mathbf{k}_\perp}) \rangle \rangle$
D	$\sum_a (T_a / V') (\partial / \partial s) [V' \{ (S_{aM} / n_a) J_{a1}^A + J_{a2}^A \}]$
P	$-(c/4\pi V') (\partial / \partial s) [V' \langle \langle (\mathbf{E} \times \mathbf{B}) \cdot \nabla_s \rangle \rangle]$
$\text{JE}_{\text{NZ}}$	$\sum_a e_a n_a \sum_{\mathbf{k}_\perp(\text{NZ})} \text{Re} \langle \langle (\mathbf{u}_{\mathbf{k}_\perp}^* \cdot \mathbf{E}_{\mathbf{k}_\perp})^{(3)} \rangle \rangle$
$\text{JE}_{\text{Z}}$	$\sum_a e_a n_a \sum_{\mathbf{k}_\perp(\text{Z})} \text{Re} \langle \langle (\mathbf{u}_{\mathbf{k}_\perp}^* \cdot \mathbf{E}_{\mathbf{k}_\perp})^{(3)} \rangle \rangle$

modes make no contribution to the radial Poynting flux,  $(c/4\pi)\sum_{\mathbf{k}_\perp(Z)}\text{Re}\langle\langle(\mathbf{E}_{\mathbf{k}_\perp}^* \times \mathbf{B}_{\mathbf{k}_\perp}) \cdot \nabla_S\rangle\rangle=0$ , and therefore, in the zonal-mode region, the Ohmic loss  $(JE_z)$  should vanish when the zonal electromagnetic energy  $(EM_z)$  reaches the steady state.

In the same manner as described above, the entropy balances for toroidal plasmas with large mean flows of the order of the ion thermal velocity can be derived as shown in Refs. 38 and 39, where the extended version of the gyrokinetic equation for rotating plasmas is used to define the toroidal momentum transport as an additional transport flux conjugate to the toroidal flow shear that appears in the gyrokinetic equation as a new thermodynamic force. For these systems with large equilibrium flows, the large mean sheared flows (not zonal flows) can be unstable to the Kelvin–Helmholtz instability and generate the turbulent entropy of nonzonal modes. This process is described by the entropy production term for nonzonal modes, which is written as the product of the momentum transport and the flow shear in the entropy balance equation.<sup>38,39</sup>

## VII. CONCLUSIONS

In this paper, the linearized model collision operator for multiple-ion-species plasmas is presented, which is applicable to the general case where the different species can have different temperatures because of the mass difference. The test- and field-particle collision parts of the model operator are given by Eq. (26) [or Eq. (31)] and Eq. (35), respectively, which satisfy conservation laws for particles, momentum, and energy, the adjointness relations, and the H-theorem. Since the adjointness relations hold, the linearized drift kinetic equation using the model collision operator can be solved for any collisional regime based on the variational principle, which is useful for calculating the neoclassical transport coefficients. For the application to the gyrokinetic equation, the test- and field-particle operators are represented in the gyrophase-averaged form shown in Eqs. (47)–(52). From the gyrokinetic equation with the collision term and the Maxwell equations, several balance equations are derived for the entropy density associated with the perturbed distribution function, the energy of electromagnetic fluctuations, the turbulent transport fluxes of particles and heat, and the collisional dissipation of turbulence. In the steady turbulence, the collisional dissipation balances with the entropy production resulting from the turbulent particle and heat fluxes driven by the thermodynamic gradient forces. Dividing the steady balance equation into the zonal and nonzonal mode parts illuminates the tendency of the zonal modes to regulate the turbulence. The entropy produced by the turbulent transport fluxes is dissipated in part by collisions in the nonzonal-mode region and in part by those in the zonal-mode region after the nonlinear entropy transfer from nonzonal to zonal modes. We can expect the contribution of zonal modes to the total collisional dissipation to increase in the case where there exist high-amplitude zonal flows that reduce nonzonal-mode amplitudes and turbulent transport fluxes.

## ACKNOWLEDGMENTS

This work has been supported in part by the Japanese Ministry of Education, Culture, Sports, Science, and Technology, Grant No. 21560861 and in part by the NIFS Collaborative Research Programs, Grant Nos. NIFS08KDAD008, NIFS08KTAL006, and NIFS09KTAL022.

## APPENDIX A: PROOF OF ADJOINTNESS RELATIONS AND BOLTZMANN'S H-THEOREM

It is shown in this appendix that the test-particle operator  $C_{ab}^T$  and the field-particle operator  $C_{ab}^F$  defined by Eqs. (26) and (35) obey the adjointness relations and Boltzmann's H-theorem shown in Eqs. (9) and (10), respectively. First, we find that  $C_{ab}^T$  and  $C_{ab}^F$  satisfy the adjointness relations as seen from

$$\begin{aligned} & \int d^3v \frac{\delta f_a}{f_{aM}} C_{ab}^T(\delta g_a) \\ &= - \int d^3v \frac{\nu_D^{ab}(v)}{2f_{aM}} \left( \mathbf{v} \times \frac{\partial(\mathcal{Q}_{ab}\delta f_a)}{\partial \mathbf{v}} \right) \cdot \left( \mathbf{v} \times \frac{\partial(\mathcal{Q}_{ab}\delta g_a)}{\partial \mathbf{v}} \right) \\ & \quad - \int d^3v \frac{v^2}{2} \nu_{\parallel}^{ab}(v) f_{aM} \left[ \frac{\partial}{\partial v} \left( \frac{\mathcal{Q}_{ab}\delta f_a}{f_{aM}} \right) \right] \left[ \frac{\partial}{\partial v} \left( \frac{\mathcal{Q}_{ab}\delta g_a}{f_{aM}} \right) \right] \\ &= \int d^3d^3v \frac{\delta g_a}{f_{aM}} C_{ab}^T(\delta f_a), \end{aligned} \quad (\text{A1})$$

and

$$\begin{aligned} T_a \int d^3v \frac{\delta f_a}{f_{aM}} C_{ab}^F(\delta f_b) &= - \gamma_{ab} \mathbf{V}_{ab}[\delta f_b] \cdot \mathbf{V}_{ba}[\delta f_a] \\ & \quad - \eta_{ab} W_{ab}[\delta f_b] W_{ba}[\delta f_a] \\ &= T_b \int d^3v \frac{\delta f_b}{f_{bM}} C_{ba}^F(\delta f_a). \end{aligned} \quad (\text{A2})$$

From Eq. (A1), we immediately obtain

$$\begin{aligned} & \int d^3d^3v \frac{\delta f_a}{f_{aM}} C_{ab}^T(\delta f_a) \\ &= - \int d^3v \frac{\nu_D^{ab}(v)}{2f_{aM}} \left| \mathbf{v} \times \frac{\partial(\mathcal{Q}_{ab}\delta f_a)}{\partial \mathbf{v}} \right|^2 \\ & \quad - \int d^3v \frac{v^2}{2} \nu_{\parallel}^{ab}(v) f_{aM} \left[ \frac{\partial}{\partial v} \left( \frac{\mathcal{Q}_{ab}\delta f_a}{f_{aM}} \right) \right]^2 \leq 0, \end{aligned} \quad (\text{A3})$$

where the necessary and sufficient condition for the equality is written as

$$\int d^3v \frac{\delta f_a}{f_{aM}} C_{ab}^T(\delta f_b) = 0 \Leftrightarrow \delta f_a = f_{aM} \delta n_a [\delta f_a] / n_a. \quad (\text{A4})$$

Here,  $\delta n_a [\delta f_a] \equiv \int d^3v \delta f_a$  is used. Let us define the inner product between two pairs of distribution functions  $(\delta f_a, \delta f_b)$  and  $(\delta g_a, \delta g_b)$  by

$$\begin{aligned} (\delta f_a, \delta f_b | \delta g_a, \delta g_b) \equiv & -T_a \int d^3v \frac{\delta f_a}{f_{aM}} C_{ab}^T(\delta g_a) \\ & - T_b \int d^3v \frac{\delta f_b}{f_{bM}} C_{ba}^T(\delta g_b), \end{aligned} \quad (\text{A5})$$

which is used to define the squared norm of  $(\delta f_a, \delta f_b)$  as

$$\|(\delta f_a, \delta f_b)\|^2 \equiv (\delta f_a, \delta f_b | \delta f_a, \delta f_b) \geq 0. \quad (\text{A6})$$

From Eq. (A4), we see that the necessary and sufficient condition for  $\|(\delta f_a, \delta f_b)\|^2 \equiv (\delta f_a, \delta f_b | \delta f_a, \delta f_b) = 0$  is given by

$$\delta f_\alpha = f_{\alpha M} \delta n_\alpha [\delta f_\alpha] / n_\alpha \quad (\alpha = a, b). \quad (\text{A7})$$

Regarding  $\|(\lambda \delta f_a - \delta g_a, \lambda \delta f_b - \delta g_b)\|^2$  as the quadratic polynomial with respect to  $\lambda$  and considering its discriminant, the Schwarz inequality is derived as

$$\|(\delta f_a, \delta f_b)\|^2 \|(\delta g_a, \delta g_b)\|^2 \geq (\delta f_a, \delta f_b | \delta g_a, \delta g_b)^2. \quad (\text{A8})$$

In Eq. (A8), the equality holds if and only if there are a pair of real numbers  $(c_1, c_2) \neq (0, 0)$  that satisfy  $\delta h_a = f_{aM} \delta n_a [\delta h_a] / n_a$  and  $\delta h_b = f_{bM} \delta n_b [\delta h_b] / n_b$  where  $\delta h_a \equiv c_1 \delta f_a + c_2 \delta g_a$  and  $\delta h_b \equiv c_1 \delta f_b + c_2 \delta g_b$ .

Now, we expand an arbitrary velocity distribution function  $F(\mathbf{v})$  as

$$F(\mathbf{v}) = \sum_{l=0}^{\infty} F^{(l)}(\mathbf{v}), \quad (\text{A9})$$

$$F^{(l)}(\mathbf{v}) = \sum_{m=-l}^l F_l^m(v) Y_l^m(\theta, \varphi),$$

where  $Y_l^m(\theta, \varphi)$  represent spherical harmonic functions and  $(v, \theta, \varphi)$  are spherical coordinates in the velocity space. Especially,  $F^{(l=1)}$  can be rewritten in the form of

$$F^{(l=1)}(\mathbf{v}) = \sum_{j=x,y,z} v_j F_j^{(l=1)}(v). \quad (\text{A10})$$

We can also divide  $F(\mathbf{v})$  into the even and odd parts with respect to the velocity  $\mathbf{v}$  as

$$F(\mathbf{v}) = F^{(\text{even})}(\mathbf{v}) + F^{(\text{odd})}(\mathbf{v}), \quad (\text{A11})$$

where

$$F^{(\text{even})}(\mathbf{v}) = \sum_{m=0}^{\infty} F^{(2m)}(\mathbf{v}), \quad (\text{A12})$$

$$F^{(\text{odd})}(\mathbf{v}) = \sum_{m=1}^{\infty} F^{(2m-1)}(\mathbf{v}).$$

Since  $C_{ab}^T$  has the rotational symmetry, we have

$$\begin{aligned} (\delta f_a, \delta f_b | \delta g_a, \delta g_b) &= \sum_{l=0}^{\infty} (\delta f_a^{(l)}, \delta f_b^{(l)} | \delta g_a^{(l)}, \delta g_b^{(l)}) \\ &= \sum_{l=0}^{\infty} \sum_{m=-l}^l (\delta f_{al}^m Y_l^m, \delta f_{bl}^m Y_l^m | \delta g_{al}^m Y_l^m, \delta g_{bl}^m Y_l^m). \end{aligned} \quad (\text{A13})$$

Using Eq. (A10), we also obtain

$$\begin{aligned} (\delta f_a^{(1)}, \delta f_b^{(1)} | \delta g_a^{(1)}, \delta g_b^{(1)}) \\ = \sum_{j=x,y,z} (v_j \delta f_{aj}^{(1)}, v_j \delta f_{bj}^{(1)} | v_j \delta g_{aj}^{(1)}, v_j \delta g_{bj}^{(1)}). \end{aligned} \quad (\text{A14})$$

In the Schwarz inequality shown in Eq. (A8), we replace  $\delta f_\alpha$  and  $\delta g_\alpha$  by  $\delta f_{\alpha j}^{(l=1)}$  ( $j=x, y, z$ ) and  $f_{\alpha M} m_\alpha v_j / T_\alpha$  ( $\alpha=a, b$ ), respectively, and find

$$\begin{aligned} 2\gamma_{ab} \left[ T_a \int d^3v \frac{\delta f_{aj}^{(1)}}{f_{aM}} C_{ab}^T(\delta f_{aj}^{(1)}) + T_b \int d^3v \frac{\delta f_{bj}^{(1)}}{f_{bM}} C_{ba}^T(\delta f_{bj}^{(1)}) \right] \\ \geq \left[ T_a \int d^3v \frac{\delta f_{aj}^{(1)}}{f_{aM}} C_{ab}^T(f_{aM} m_a v_j / T_a) \right. \\ \left. + T_b \int d^3v \frac{\delta f_{bj}^{(1)}}{f_{bM}} C_{ba}^T(f_{bM} m_b v_j / T_b) \right]^2 \\ \geq 4T_a \int d^3v \frac{\delta f_{aj}^{(1)}}{f_{aM}} C_{ab}^T(f_{aM} m_a v_j / T_a) \\ \times T_b \int d^3v \frac{\delta f_{bj}^{(1)}}{f_{bM}} C_{ba}^T(f_{bM} m_b v_j / T_b), \end{aligned} \quad (\text{A15})$$

where the definition of  $\gamma_{ab} (< 0)$  in Eq. (40) is used. Using Eq. (A15) and the field-particle collision operator defined in Eq. (35), we obtain

$$\begin{aligned} T_a \int d^3v \frac{\delta f_a^{(\text{odd})}}{f_{aM}} [C_{ab}^T(\delta f_a^{(\text{odd})}) + C_{ab}^F(\delta f_b^{(\text{odd})})] \\ + T_b \int d^3v \frac{\delta f_b^{(\text{odd})}}{f_{bM}} [C_{ba}^T(\delta f_b^{(\text{odd})}) + C_{ba}^F(\delta f_a^{(\text{odd})})] \\ \leq T_a \int d^3v \frac{\delta f_a^{(1)}}{f_{aM}} [C_{ab}^T(\delta f_a^{(1)}) + C_{ab}^F(\delta f_b^{(1)})] \\ + T_b \int d^3v \frac{\delta f_b^{(1)}}{f_{bM}} [C_{ba}^T(\delta f_b^{(1)}) + C_{ba}^F(\delta f_a^{(1)})] \leq 0, \end{aligned} \quad (\text{A16})$$

where the left-hand side vanishes if and only if

$$\delta f_\alpha^{(\text{odd})} = \delta f_\alpha^{(1)} = f_{\alpha M} \frac{m_\alpha}{T_\alpha} \mathbf{u}_\alpha [\delta f_\alpha] \cdot \mathbf{v} \quad (\alpha = a, b), \quad (\text{A17})$$

$$\mathbf{u}_a [\delta f_a] = \mathbf{u}_b [\delta f_b].$$

Next, substituting  $\delta f_\alpha^{(\text{even})}$  and  $f_{M\alpha} x_\alpha^2$  into  $\delta f_\alpha$  and  $\delta g_\alpha$  ( $\alpha=a, b$ ), respectively, in the Schwarz inequality shown by Eq. (A8) leads to

$$\begin{aligned}
& 2\eta_{ab} \left[ T_a \int d^3v \frac{\delta f_a^{(\text{even})}}{f_{aM}} C_{ab}^T(\delta f_a^{(\text{even})}) \right. \\
& \quad \left. + T_b \int d^3v \frac{\delta f_b^{(\text{even})}}{f_{bM}} C_{ba}^T(\delta f_b^{(\text{even})}) \right] \\
& \geq \left[ T_a \int d^3v \frac{\delta f_a^{(\text{even})}}{f_{aM}} C_{ab}^T(f_{aM}x_a^2) \right. \\
& \quad \left. + T_b \int d^3v \frac{\delta f_b^{(\text{even})}}{f_{bM}} C_{ba}^T(f_{bM}x_b^2) \right]^2 \\
& \geq 4T_a \int d^3v \frac{\delta f_a^{(\text{even})}}{f_{aM}} C_{ab}^T(f_{aM}x_a^2) \\
& \quad \times T_b \int d^3v \frac{\delta f_b^{(\text{even})}}{f_{bM}} C_{ba}^T(f_{bM}x_b^2), \tag{A18}
\end{aligned}$$

where  $\eta_{ab}(<0)$  is defined in Eq. (41). Equation (A18) is rewritten by using Eqs. (35) as

$$\begin{aligned}
& T_a \int d^3v \frac{\delta f_a^{(\text{even})}}{f_{aM}} [C_{ab}^T(\delta f_a^{(\text{even})}) + C_{ab}^F(\delta f_b^{(\text{even})})] \\
& \quad + T_b \int d^3v \frac{\delta f_b^{(\text{even})}}{f_{bM}} [C_{ba}^T(\delta f_b^{(\text{even})}) + C_{ba}^F(\delta f_a^{(\text{even})})] \leq 0, \tag{A19}
\end{aligned}$$

where the equality is satisfied only when

$$\begin{aligned}
\delta f_\alpha^{(\text{even})} &= f_{\alpha M} \left[ \frac{n_\alpha[\delta f_\alpha]}{n_\alpha} + \frac{\delta T_\alpha[\delta f_\alpha]}{T_\alpha} \left( x_\alpha^2 - \frac{3}{2} \right) \right] \\
& \quad (\alpha = a, b), \tag{A20} \\
\frac{\delta T_a[\delta f_a]}{T_a} &= \frac{\delta T_b[\delta f_b]}{T_b}.
\end{aligned}$$

Finally, Eqs. (A16) and (A19) are combined to yield the H-theorem,

$$\begin{aligned}
& T_a \int d^3v \frac{\delta f_a}{f_{aM}} [C_{ab}^T(\delta f_a) + C_{ab}^F(\delta f_b)] \\
& \quad + T_b \int d^3v \frac{\delta f_b}{f_{bM}} [C_{ba}^T(\delta f_b) + C_{ba}^F(\delta f_a)] \leq 0, \tag{A21}
\end{aligned}$$

where the necessary and sufficient conditions for the left-hand side to vanish are given by

$$\begin{aligned}
\delta f_\alpha &= f_{\alpha M} \left[ \frac{n_\alpha[\delta f_\alpha]}{n_\alpha} + \frac{m_\alpha}{T_\alpha} \mathbf{u}_\alpha[\delta f_\alpha] \cdot \mathbf{v} + \frac{\delta T_\alpha[\delta f_\alpha]}{T_\alpha} \left( x_\alpha^2 - \frac{3}{2} \right) \right] \\
& \quad (\alpha = a, b), \tag{A22} \\
\mathbf{u}_a[\delta f_a] &= \mathbf{u}_b[\delta f_b], \quad \frac{\delta T_a[\delta f_a]}{T_a} = \frac{\delta T_b[\delta f_b]}{T_b}.
\end{aligned}$$

## APPENDIX B: GYROCENTER DISTRIBUTION FUNCTION

In the electrostatic gyrokinetic turbulence such as the ITG turbulence, the perturbed *gyrocenter* distribution function  $\delta f_{\mathbf{ak}_\perp}^{(g)}$ , which is independent of the gyrophase, is defined by

$$\delta f_{\mathbf{ak}_\perp}^{(g)} = -J_0(k_\perp \rho_a) \frac{e_a \phi_{\mathbf{k}_\perp}}{T_a} f_{aM} + h_{\mathbf{ak}_\perp}, \tag{B1}$$

where  $h_{\mathbf{ak}_\perp}$  represents the adiabatic part of the perturbed *particle* distribution function  $\delta f_{\mathbf{ak}_\perp}$  as shown in Eq. (42). Then, using Eqs. (42) and (B1),  $\delta f_{\mathbf{ak}_\perp}$  is written as

$$\delta f_{\mathbf{ak}_\perp} = e^{-i\mathbf{k}_\perp \cdot \boldsymbol{\rho}_a} \delta f_{\mathbf{ak}_\perp}^{(g)} - \frac{e_a \phi_{\mathbf{k}_\perp}}{T_a} f_{aM} [1 - e^{-i\mathbf{k}_\perp \cdot \boldsymbol{\rho}_a} J_0(k_\perp \rho_a)]. \tag{B2}$$

On the right-hand side of Eq. (B2), the factor  $e^{-i\mathbf{k}_\perp \cdot \boldsymbol{\rho}_a}$  in the first term results from the difference between the particle and gyrocenter positions while the second group of terms represents the polarization, which is the variation of the particle distribution due to the potential perturbation.

Using Eq. (B1), we can rewrite Eq. (54), which represents the contribution from the turbulent fluctuation with the wave number vector  $\mathbf{k}_\perp$  to the turbulent entropy variable  $\delta S_a$ , as

$$\begin{aligned}
& \int d^3v \frac{|\delta f_{\mathbf{ak}_\perp}|^2}{2f_{aM}} \\
& = \int d^3v \frac{|\delta f_{\mathbf{ak}_\perp}^{(g)}|^2}{2f_{aM}} + \frac{n_a e_a^2}{2T_a^2} |\phi_{\mathbf{k}_\perp}|^2 [1 - \Gamma_0(b_a)]. \tag{B3}
\end{aligned}$$

The expression for the turbulent entropy variable given in Eq. (B3), where the contributions from the gyrocenter distribution function and the polarization part are separately shown, is often used in the literature of the gyrokinetic ITG turbulence simulations.<sup>29,30</sup>

## APPENDIX C: GYROKINETIC MAXWELL EQUATIONS

Based on the gyrokinetic ordering, the lowest-order (first-order) perturbed electromagnetic fields are written in terms of the electrostatic potential  $\phi_{\mathbf{k}_\perp}$  and the vector potential  $\mathbf{A}_{\mathbf{k}_\perp}$  as

$$\mathbf{E}_{\mathbf{k}_\perp} = -i\mathbf{k}_\perp \phi_{\mathbf{k}_\perp}, \tag{C1}$$

$$\mathbf{B}_{\mathbf{k}_\perp} = i\mathbf{k}_\perp \times \mathbf{A}_{\mathbf{k}_\perp},$$

and the second-order electromagnetic fields are given by

$$\mathbf{E}_{\mathbf{k}_\perp}^{(2)} = -\nabla \phi_{\mathbf{k}_\perp} - \frac{1}{c} \frac{\partial \mathbf{A}_{\mathbf{k}_\perp}}{\partial t}, \tag{C2}$$

$$\mathbf{B}_{\mathbf{k}_\perp}^{(2)} = \nabla \times \mathbf{A}_{\mathbf{k}_\perp}.$$

In the eikonal representation such as  $\phi(\mathbf{x}, t) = \sum_{\mathbf{k}_\perp} \phi_{\mathbf{k}_\perp}(\mathbf{x}, t) \exp[iS_{\mathbf{k}_\perp}(\mathbf{x})]$  with  $\mathbf{k}_\perp = \nabla S_{\mathbf{k}_\perp}$ , the rapid perpendicular variation is described by the oscillatory factor

$\exp[iS_{\mathbf{k}_\perp}(\mathbf{x})]$  while the amplitude  $\phi_{\mathbf{k}_\perp}$  still has a slow dependence on the particle position  $\mathbf{x}$ . In Eq. (C2), the gradient operator  $\nabla$  acts only on the slowly varying amplitude part and therefore  $|\nabla| \ll k_\perp$ . The turbulent electromagnetic fields are linked to the charge density  $\sum_a e_a \delta n_{a\mathbf{k}_\perp}$  and the current density  $\sum_a n_a e_a \mathbf{u}_{a\mathbf{k}_\perp}$  through the Maxwell equations. The first-order perturbed density  $\delta n_{a\mathbf{k}_\perp} \equiv \int d^3v \delta f_{a\mathbf{k}_\perp}$  and flow velocity  $\mathbf{u}_{a\mathbf{k}_\perp} \equiv \int d^3v \delta f_{a\mathbf{k}_\perp} \mathbf{v}$  are given by

$$\delta n_{a\mathbf{k}_\perp} = n_a e_a \phi_{\mathbf{k}_\perp} / T_a + \int d^3v h_{a\mathbf{k}_\perp} J_0(k_\perp v_\perp / \Omega_a), \quad (\text{C3})$$

$$n_a \mathbf{u}_{a\mathbf{k}_\perp} = \mathbf{b} \int d^3v v_\parallel h_{a\mathbf{k}_\perp} J_0(k_\perp v_\perp / \Omega_a) - i(\mathbf{k} \times \mathbf{b} / k_\perp) \int d^3v v_\perp h_{a\mathbf{k}_\perp} J_1(k_\perp v_\perp / \Omega_a),$$

where the first-order perturbed distribution function  $\delta f_{a\mathbf{k}_\perp}$  given in Eq. (42) is used. Using Eq. (C3), the lowest-order Maxwell equations are given by Poisson's equation,

$$(k_\perp^2 + \lambda_D^{-2}) \phi_{\mathbf{k}_\perp} = 4\pi \sum_a e_a \int d^3v h_{a\mathbf{k}_\perp} J_0(k_\perp v_\perp / \Omega_a), \quad (\text{C4})$$

and the parallel and perpendicular components of Ampère's law written as

$$k_\perp^2 A_{\parallel \mathbf{k}_\perp} = \frac{4\pi}{c} \sum_a e_a \int d^3v v_\parallel h_{a\mathbf{k}_\perp} J_0(k_\perp v_\perp / \Omega_a), \quad (\text{C5})$$

$$-k_\perp B_{\parallel \mathbf{k}_\perp} = \frac{4\pi}{c} \sum_a e_a \int d^3v v_\perp h_{a\mathbf{k}_\perp} J_1(k_\perp v_\perp / \Omega_a),$$

where  $\lambda_D \equiv (\sum_a 4\pi n_a e_a^2 / T_a)^{-1/2}$  and  $B_{\parallel \mathbf{k}_\perp} \equiv \mathbf{B}_{\mathbf{k}_\perp} \cdot \mathbf{b} \equiv i(\mathbf{k}_\perp \times \mathbf{A}_{\mathbf{k}_\perp}) \cdot \mathbf{b}$ . The displacement current appears on the next order of the Maxwell equation,

$$\nabla \times \mathbf{B}_{\mathbf{k}_\perp} = \frac{4\pi}{c} \sum_a n_a e_a \mathbf{u}_{a\mathbf{k}_\perp}^{(2)} + \frac{1}{c} \frac{\partial \mathbf{E}_{\mathbf{k}_\perp}}{\partial t}, \quad (\text{C6})$$

where  $\mathbf{u}_{a\mathbf{k}_\perp}^{(2)}$  represents the second-order flow velocity. We find from Eq. (C3) that the first-order flow,  $\mathbf{u}_{a\mathbf{k}_\perp}$ , satisfies the incompressible condition,  $\mathbf{k}_\perp \cdot \mathbf{u}_{a\mathbf{k}_\perp} = 0$ , as the lowest-order continuity equation. The next-order continuity equation for the perturbed density  $\delta n_a \equiv \int d^3v \delta f_a$  is written as

$$\frac{\partial \delta n_{a\mathbf{k}_\perp}}{\partial t} + \nabla \cdot (n_a \mathbf{u}_{a\mathbf{k}_\perp}) = -i n_a \mathbf{k}_\perp \cdot \mathbf{u}_{\perp a\mathbf{k}_\perp}^{(2)}. \quad (\text{C7})$$

Since  $\mathbf{k}_\perp \cdot \mathbf{u}_{a\mathbf{k}_\perp} = 0$ , we find  $\mathbf{u}_{a\mathbf{k}_\perp} \cdot \mathbf{E}_{\mathbf{k}_\perp} = 0$  from Eq. (C1). Then, the lowest-order nonvanishing part of the inner product of the flow velocity and the electric field is the third-order quantity given by

$$n_a \text{Re}(\mathbf{u}_{a\mathbf{k}_\perp}^* \cdot \mathbf{E}_{\mathbf{k}_\perp})^{(3)} \equiv n_a \text{Re}(\mathbf{u}_{a\mathbf{k}_\perp}^* \cdot \mathbf{E}_{\mathbf{k}_\perp}^{(2)} + \mathbf{u}_{a\mathbf{k}_\perp}^{(2)*} \cdot \mathbf{E}_{\mathbf{k}_\perp}) = -\text{Re} \left[ \phi_{\mathbf{k}_\perp}^* \frac{\partial \delta n_{\perp a\mathbf{k}_\perp}}{\partial t} + \nabla \cdot (\phi_{\mathbf{k}_\perp}^* n_a \mathbf{u}_{a\mathbf{k}_\perp}) + \frac{1}{c} \frac{\partial \mathbf{A}_{\mathbf{k}_\perp}^*}{\partial t} \cdot n_a \mathbf{u}_{a\mathbf{k}_\perp} \right]. \quad (\text{C8})$$

From Eqs. (C2), (C5), (C6), and (C8), we can derive the equation for the energy of electromagnetic fluctuations,

$$\frac{1}{8\pi} \frac{\partial}{\partial t} (|\mathbf{E}_{\mathbf{k}_\perp}|^2 + |\mathbf{B}_{\mathbf{k}_\perp}|^2) = -\text{Re} \left[ \frac{c}{4\pi} \nabla \cdot (\mathbf{E}_{\mathbf{k}_\perp}^* \times \mathbf{B}_{\mathbf{k}_\perp}) + \sum_a e_a n_a (\mathbf{u}_{a\mathbf{k}_\perp}^* \cdot \mathbf{E}_{\mathbf{k}_\perp})^{(3)} \right], \quad (\text{C9})$$

where the first and second terms on the right-hand side represent the energy inflow due to the Poynting flux and the energy loss caused by the Joule heating, respectively. Using Eqs. (C1) and (C5), the relation between the turbulent entropy transport given in Eq. (55) and the Poynting flux is obtained as

$$\sum_a T_a \int d^3v \frac{1}{2f_{aM}} (|\delta f_{a\mathbf{k}_\perp}|^2 v - |h_{a\mathbf{k}_\perp}|^2 v_\parallel \mathbf{b}) = -\frac{c}{4\pi} \text{Re}(\mathbf{E}_{\mathbf{k}_\perp}^* \times \mathbf{B}_{\mathbf{k}_\perp}). \quad (\text{C10})$$

- <sup>1</sup>A. M. Dimits, G. Bateman, M. A. Beer, B. I. Cohen, W. Dorland, G. W. Hammett, C. Kim, J. E. Kinsey, M. Kotschenreuther, A. H. Kritiz, L. L. Lao, J. Mandrekas, W. M. Nevins, S. E. Parker, A. J. Redd, D. E. Shumaker, R. Sydora, and J. Weiland, *Phys. Plasmas* **7**, 969 (2000).
- <sup>2</sup>Y. Idomura, T.-H. Watanabe, and H. Sugama, *C. R. Phys.* **7**, 650 (2006).
- <sup>3</sup>F. L. Hinton and R. D. Hazeltine, *Rev. Mod. Phys.* **48**, 239 (1976).
- <sup>4</sup>S. P. Hirshman and D. J. Sigmar, *Nucl. Fusion* **21**, 1079 (1981).
- <sup>5</sup>E. A. Frieman and L. Chen, *Phys. Fluids* **25**, 502 (1982).
- <sup>6</sup>P. Helander and D. J. Sigmar, *Collisional Transport in Magnetized Plasmas* (Cambridge University Press, Cambridge, 2002), Chap. 3.
- <sup>7</sup>I. G. Abel, M. Barnes, S. C. Cowley, W. Dorland, and A. A. Schekochihin, *Phys. Plasmas* **15**, 122509 (2008).
- <sup>8</sup>Z. Lin, M. W. Tang, and W. W. Lee, *Phys. Plasmas* **2**, 2975 (1995).
- <sup>9</sup>W. X. Wang, N. Nakajima, M. Okamoto, and S. Murakami, *Plasma Phys. Controlled Fusion* **41**, 1091 (1999).
- <sup>10</sup>P. J. Catto and K. T. Tsang, *Phys. Fluids* **20**, 396 (1977).
- <sup>11</sup>X. Q. Xu and M. N. Rosenbluth, *Phys. Fluids B* **3**, 627 (1991).
- <sup>12</sup>A. M. Dimits and B. I. Cohen, *Phys. Rev. E* **49**, 709 (1994).
- <sup>13</sup>S. P. Hirshman and D. J. Sigmar, *Phys. Fluids* **19**, 1532 (1976).
- <sup>14</sup>M. N. Rosenbluth, R. D. Hazeltine, and F. L. Hinton, *Phys. Fluids* **15**, 116 (1972).
- <sup>15</sup>H. Sugama and W. Horton, *Phys. Plasmas* **3**, 304 (1996).
- <sup>16</sup>H. Sugama and S. Nishimura, *Phys. Plasmas* **9**, 4637 (2002); H. Sugama and T.-H. Watanabe, *ibid.* **15**, 042502 (2008).
- <sup>17</sup>J. A. Krommes and G. Hu, *Phys. Fluids B* **5**, 3908 (1993).
- <sup>18</sup>H. Sugama, M. Okamoto, W. Horton, and M. Wakatani, *Phys. Plasmas* **3**, 2379 (1996).
- <sup>19</sup>P. H. Diamond, S.-I. Itoh, K. Itoh, and T. S. Hahm, *Plasma Phys. Controlled Fusion* **47**, R35 (2005).
- <sup>20</sup>K. Itoh, S.-I. Itoh, P. H. Diamond, A. Fujisawa, G. R. Tynan, M. Yagi, and Y. Nagashima, *Phys. Plasmas* **13**, 055502 (2006).
- <sup>21</sup>A. Fujisawa, *Nucl. Fusion* **49**, 013001 (2009).
- <sup>22</sup>Z. Lin, T. S. Hahm, W. W. Lee, W. M. Tang, and R. B. White, *Science* **281**, 1835 (1998).
- <sup>23</sup>T.-H. Watanabe, H. Sugama, and S. Ferrando-Margalet, *Phys. Rev. Lett.*



- 100**, 195002 (2008); H. Sugama, T.-H. Watanabe, and S. Ferrando-Margalet, *Plasma Fusion Res.* **3**, 041 (2008).
- <sup>24</sup>R. D. Hazeltine and J. D. Meiss, *Plasma Confinement* (Addison-Wesley, Redwood City, California, 1992), p. 298.
- <sup>25</sup>A. A. Schekochihin, S. C. Cowley, W. Dorland, G. W. Hammett, G. G. Howes, E. Quataert, and T. Tatsuno, *Astrophys. J., Suppl.* **182**, 310 (2009).
- <sup>26</sup>T. M. Antonsen, Jr., and B. Lane, *Phys. Fluids* **23**, 1205 (1980).
- <sup>27</sup>H. Sugama and W. Horton, *Phys. Plasmas* **2**, 2989 (1995).
- <sup>28</sup>W. Horton, *Rev. Mod. Phys.* **71**, 735 (1999).
- <sup>29</sup>T.-H. Watanabe and H. Sugama, *Nucl. Fusion* **46**, 24 (2006).
- <sup>30</sup>J. Candy and R. E. Waltz, *Phys. Plasmas* **13**, 032310 (2006).
- <sup>31</sup>T.-H. Watanabe and H. Sugama, *Phys. Plasmas* **9**, 3659 (2002); **11**, 1476 (2004).
- <sup>32</sup>H. Sugama and T.-H. Watanabe, *Phys. Plasmas* **10**, 726 (2003).
- <sup>33</sup>P. Ricci, B. N. Rogers, and W. Dorland, *Phys. Rev. Lett.* **97**, 245001 (2006).
- <sup>34</sup>P. H. Diamond, Y.-M. Liang, B. A. Carreras, and P. W. Terry, *Phys. Rev. Lett.* **72**, 2565 (1994).
- <sup>35</sup>B. A. Carreras, D. Newman, P. H. Diamond, and Y.-M. Liang, *Phys. Plasmas* **1**, 4014 (1994).
- <sup>36</sup>H. Sugama and W. Horton, *Phys. Plasmas* **1**, 345 (1994); *Plasma Phys. Controlled Fusion* **37**, 345 (1995).
- <sup>37</sup>H. Sugama, T.-H. Watanabe, and W. Horton, *Phys. Plasmas* **8**, 2617 (2001).
- <sup>38</sup>H. Sugama and W. Horton, *Phys. Plasmas* **4**, 405 (1997); **5**, 2560 (1998).
- <sup>39</sup>H. Sugama and W. Horton, *J. Plasma Phys.* **59**, 695 (1998).