

## §6. Analysis of Turbulent Structures by the Correlation ECE Radiometer

Kogi, Y., Matsukawa, S., Mukunoki, H. (Fukuoka Inst. Tech.),  
 Mase, A. (ASTEC, Kyushu Univ.),  
 Kuwahara, D. (Tokyo Tech.),  
 Tokuzawa, T., Tamura, N., Tsuchiya, H., Nagayama, Y.,  
 Kawahata, K.,  
 Yoshinaga, T. (NDA)

It is considered that a turbulence in a plasma transports stored energy from a core region to outer confinement region of a plasma. Therefore, it is important to measure turbulences to study relation between quality of the confinement and turbulences. The final goal of this study is to apply turbulence diagnostics to a turbulence suppression control. Here, purpose of this study is measurement of turbulent components in an electron temperature. An electron cyclotron emission (ECE) radiometer is often used to measure an electron temperature, as well as its profile. Capability of measurement at a specific local position is an advantage in the turbulence transport study. However, a noise component, that attribute that an ECE radiometer measures number of photons, is always generated. This noise component is expressed as follows.

$$\tilde{T}_r = \frac{T_e + T_{noise}}{\sqrt{1 + \frac{RBW}{2VBW}}} \cong \frac{T_e}{7} \quad (1)$$

$T_{noise}$  is noise temperature of a measurement system. RBW is a bandwidth of the band-pass filter that limits frequencies of ECE, that are detected by a radiometer. VBW is a bandwidth of a video signal, that is sampled by an ADC. Here,  $T_{noise}$ , RBW, and VBW are 0 (assumption), 100MHz, 1MHz, respectively. The resultant noise component attains  $T_e/7$  as shown in Eq. (1). This noise component is too large to mask temperature components of turbulences. Therefore, we need to use multi-channel measurement system to apply correlation analysis. The correlation analysis reduces the VBW in Eq. (1); therefore, the noise component is also reduced. For example, the amplitude of the noise component becomes  $T_e/700$  when the correlation analysis that uses data duration of 10ms is applied. Wider the data duration is used, less noise component is achieved.

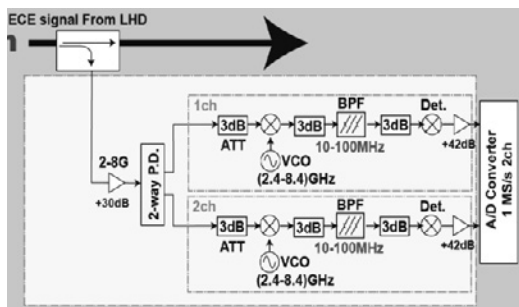

Fig.1 2channel correlation ECE radiometer system

Fig. 1 shows a block diagram of two channel ECE radiometer system. We have applied this preliminary system to the LHD plasma in the last experimental campaign. This system uses the existent ECE radiometer signal (RADH-L). Existent 1<sup>st</sup> IF signal is divided, and is introduced to our correlation ECE system. The signal is divided into two signals. Each signal is mixed with local oscillator (LO) signal with different frequency. The LO frequency sets the measurement local position in the plasma. This system can detect the ECE signal with frequencies between 123.6 GHz and 129.6 GHz. Band-pass filters limit the bandwidth of the mixer output signal (intermediate frequency (IF) signal) strictly. Then these filtered signals are amplified and sampled by the ADC.

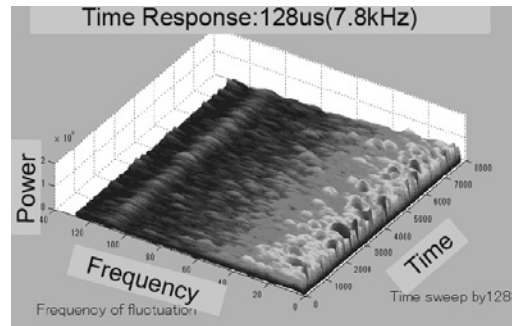

Fig. 2 Time evolution of the cross-spectral density.

Fig. 2 shows an example of the cross spectral density. The cross-spectral density is calculated by FFT (convolution(ch1,ch2)). As mentioned above, noise level is decreasing in increasing in the duration of the data used for the analysis. However, this analysis uses fast Fourier transform (FFT); therefore, periodical signal must be steadily excited during the data. This means that relationship between the effect of noise suppression by widen the data length and the effect of amplitude enhancement by the FFT analysis with short data duration is trade-off. We have applied this analysis by changing the duration of the data used for the analysis, however, clear peaks have not been detected yet.

In the next experimental campaign, we plan to apply 16 channel correlation ECE radiometer system to the LHD plasma. We also plan to apply convolution analysis without the FFT. This analysis does not require steady state periodical signal, that help to reveal non-steady signal like a perturbation.