

Wide Dynamic Range Neutron Flux Monitor Having Fast Time Response for the Large Helical Device

| | |
|-------|--|
| メタデータ | 言語: eng 出版者: 公開日: 2015-04-21 キーワード (Ja): キーワード (En): 作成者: Isobe, M., Ogawa, K., Miyake, H., Hayashi, H., Kobuchi, T., Nakano, Y., Watanabe, K., Uritani, A., Misawa, T., Nishitani, T., Tomitaka, M., Kumagai, T., Mashiyama, Y., Ito, D., Kono, S., Yamauchi, M., Takeiri, Y. メールアドレス: 所属: |
| URL | http://hdl.handle.net/10655/12478 |

This work is licensed under a Creative Commons
Attribution-NonCommercial-ShareAlike 3.0
International License.



Wide dynamic range neutron flux monitor having fast time response for the Large Helical Device

Cite as: Rev. Sci. Instrum. **85**, 11E114 (2014); <https://doi.org/10.1063/1.4891049>

Submitted: 28 May 2014 • Accepted: 10 July 2014 • Published Online: 04 August 2014

M. Isobe, K. Ogawa, H. Miyake, et al.



View Online



Export Citation



CrossMark

ARTICLES YOU MAY BE INTERESTED IN

[In situ calibration of neutron activation system on the large helical device](#)

Review of Scientific Instruments **88**, 113302 (2017); <https://doi.org/10.1063/1.5009475>

[The large helical device vertical neutron camera operating in the MHz counting rate range](#)

Review of Scientific Instruments **89**, 113509 (2018); <https://doi.org/10.1063/1.5054818>

[Progress in development of the neutron profile monitor for the large helical device](#)

Review of Scientific Instruments **85**, 11E110 (2014); <https://doi.org/10.1063/1.4890399>

Webinar

Interfaces: how they make
or break a nanodevice

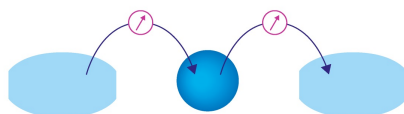

March 29th – Register now



Zurich
Instruments



Wide dynamic range neutron flux monitor having fast time response for the Large Helical Device^{a)}

M. Isobe,^{1,2,b)} K. Ogawa,¹ H. Miyake,¹ H. Hayashi,¹ T. Kobuchi,¹ Y. Nakano,³ K. Watanabe,³ A. Uritani,³ T. Misawa,⁴ T. Nishitani,⁵ M. Tomitaka,⁶ T. Kumagai,⁶ Y. Mashiyama,⁶ D. Ito,⁶ S. Kono,⁶ M. Yamauchi,⁷ and Y. Takeiri^{1,2}

¹National Institute for Fusion Science, Toki 509-5292, Japan

²Department of Fusion Science, The Graduate University for Advanced Studies, Toki 509-5292, Japan

³Department of Materials, Physics and Energy Engineering, Nagoya University, Nagoya 464-8603, Japan

⁴Kyoto University Research Reactor Institute, Kumatori 590-0494, Japan

⁵Japan Atomic Energy Agency, Rokkasho 039-3212, Japan

⁶Toshiba Corporation, Fuchu 183-8511, Japan

⁷Toshiba Nuclear Engineering Services Corporation, Yokohama 235-8523, Japan

(Presented 3 June 2014; received 28 May 2014; accepted 10 July 2014; published online 4 August 2014)

A fast time response, wide dynamic range neutron flux monitor has been developed toward the LHD deuterium operation by using leading-edge signal processing technologies providing maximum counting rate up to $\sim 5 \times 10^9$ counts/s. Because a maximum total neutron emission rate over 1×10^{16} n/s is predicted in neutral beam-heated LHD plasmas, fast response and wide dynamic range capabilities of the system are essential. Preliminary tests have demonstrated successful performance as a wide dynamic range monitor along the design. © 2014 AIP Publishing LLC. [<http://dx.doi.org/10.1063/1.4891049>]

I. INTRODUCTION

The Large Helical Device (LHD), based at the National Institute for Fusion Science (NIFS), Japan, is the largest superconducting heliotron-type magnetic confinement system, providing an excellent opportunity to investigate three-dimensional currentless plasmas.¹ The LHD achieved its first plasma discharge with hydrogen gas on March 31, 1998.² So far, high β , high ion and electron temperatures, and long pulse operation capabilities in hydrogen or helium discharges have been demonstrated in the LHD. To explore higher-performance plasmas and to obtain a prospect toward a helical fusion reactor, the LHD project will step into a new stage, i.e., deuterium experiments. The deuterium experiment project on LHD has recently begun.³ The experiment campaign will continue for nine years. For the reason of radiation safety, a neutron yield limit, a so-called neutron budget, will be set each year. In the first six years, the maximum annual integrated yield of neutron is 2.1×10^{19} . For the latter three years, the maximum annual neutron yield is set to be slightly higher, 3.2×10^{19} , because an integrated high-performance experiment is planned. To execute this project as scheduled steadily and safely, a neutron monitoring system is essentially required in terms of both plasma physics and radiation safety. In LHD, the maximum neutron emission rate is expected to be over 1×10^{16} n/s when full power heating by high-energy deuterium neutral beam injection (NBI) is performed.⁴ In addition, the neutron emission

rate can change largely according to the injection pattern of NBI. It also changes rapidly within a time scale of the beam ion's slowing down time after the NBI is turned off. For the reasons above, a fast-response, wide dynamics range neutron flux monitor (NFM) is required in LHD.⁵ In large tokamaks such as Tokamak Fusion Test Reactor (TFTR) and JAERI Tokamak-60 Upgrade (JT-60U), a wide dynamic range ex-vessel NFM consisting of ²³⁵U fission chamber, preamplifier, and pulse counting-Campbell electronics⁶ had been primarily employed. Note that the NFMs for TFTR and JT-60U were developed or fabricated in the early 1980s^{7,8} and 1990s,⁹ respectively. The electronics is based on traditional analog circuits and is no longer commercially available at this moment. Therefore, we have been developing NFM optimized for LHD by using leading-edge digital processing technologies. This paper describes characterization of neutron field around the LHD torus, ex-vessel NFM system, in particular, the digital-signal-processing (DSP) unit, test operation result of DSP unit prototype at Kyoto University Critical Assembly (KUCA),¹⁰ and efforts toward *in situ* calibration of NFM.

II. EX-VESSEL NEUTRON FLUX MONITOR DEVELOPED FOR LHD

A. Detector and its arrangement on LHD

Neutron field around the LHD torus has been characterized by using two different-type codes, i.e., a two-dimensional neutron and photon transport code DOT-3.5/DORT,⁴ and a three-dimensional code MCNP.¹¹⁻¹⁴ Characterization of neutron field near the machine is indispensable to choose sensitivity and location of the thermal-neutron detector used in the ex-vessel NFM system. As an example, spatial distributions of neutron and secondary γ -ray fluxes at the

^{a)}Contributed paper, published as part of the Proceedings of the 20th Topical Conference on High-Temperature Plasma Diagnostics, Atlanta, Georgia, USA, June 2014.

^{b)}Author to whom correspondence should be addressed. Electronic mail: isobe@nifs.ac.jp

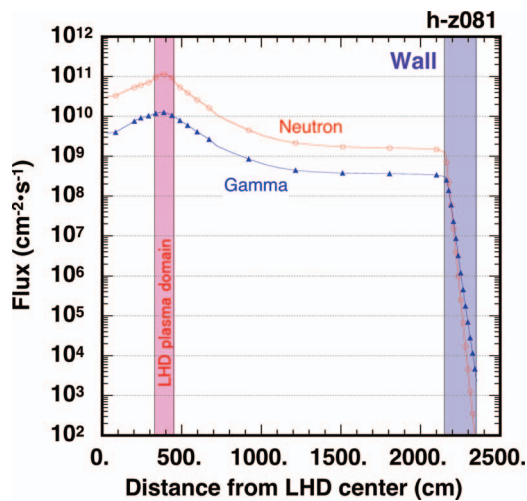

FIG. 1. Neutron and γ -ray flux distributions at the equatorial plane of the LHD calculated by the DORT code. Axisymmetry of horizontally elongated cross section and expected maximum neutron emission rate are assumed.

equatorial plane of the machine in the LHD torus hall are shown for a deuterium discharge where the maximum neutron rate is expected. This calculation was performed as a part of radiation shielding analysis for the LHD torus hall by using the DORT code. Although LHD has intrinsically the complicated three-dimensional structure, axisymmetry of horizontally elongated cross section is assumed in this model because the DORT code is not applicable to full three-dimensional calculation. As can be seen in Fig. 1, neutron flux is expected to be 10^9 – 10^{10} $\text{cm}^{-2}\text{s}^{-1}$ in a range of 8–10 m from the machine axis where ^{235}U fission chamber will be placed. Here, we assume that all neutrons are thermalized at the detector location by using a moderator. Although pulse counting-Campbell system offers very high counting rate capability up to $\sim 5 \times 10^9$ counts/s, the NFM should be operated below its maximum counting rate capability. To guarantee the condition above mentioned, we choose a ^{235}U fission chamber, KSA type of TOSHIBA Electron Tubes and Devices Co., LTD having thermal neutron sensitivity of 0.1 counts/s/nv. This chamber is the same as that employed in JT-60U deuterium operation.¹⁵ Expected counting rate of the NFM system with this chamber is in a range of 10^8 – 10^9 counts/s. Actually, more precise evaluations on neutron transport and expected neutron counting rate in the full three-dimensional configuration have been carried out by using the MCNP code.^{11–14} It should be noted that neutron flux around the torus evaluated by the MCNP code is in the same order with that computed by the DORT code. LHD will be equipped with three ex-vessel NFM's to secure safe machine operation and radiation safety. Each chamber will be installed around the torus as shown in Fig. 2. Three preamplifiers will be located in the basement of the LHD torus hall. The NFM DSP unit having both functions of pulse counting-Campbell modes will be placed in a diagnostics room, i.e., a non-radiation controlled area. Because the cable between the chamber and preamplifier is quite long, about 40 m, the effect of electromagnetic noise was a great concern for us. We therefore checked noise level in the actual LHD environment in October 2011

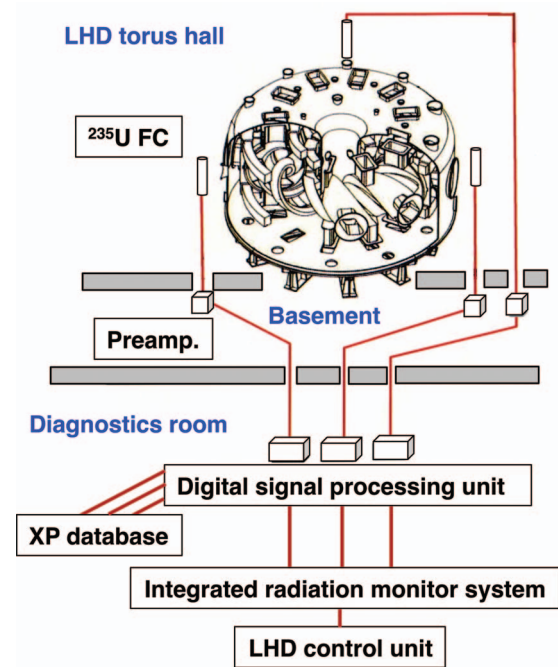

FIG. 2. Arrangement of the NFM system on the LHD.

by using an imitation chamber consisting of capacitor and a TOSHIBA DSP unit used in start-up range neutron flux monitor of Advanced Boiling Water Reactor. This test indicates that the noise level is acceptable and the entire system can work in the LHD environment. Three ^{235}U fission chambers will play a primary role in assessing total neutron emission rate in middle and high neutron yield shots of LHD. Note that in addition to three fission chambers, we will also employ three high-sensitivity thermal neutron detectors, i.e., a ^{10}B detector of TOSHIBA E6863-558 having sensitivity of 6.5 counts/s/nv and two ^3He detectors with sensitivity of 39 counts/s/nv of TOSHIBA E6862-500 to enlarge further dynamic range of the system. These detectors are operated in the pulse counting mode and will be collocated with each ^{235}U fission chamber. Because ^{10}B and ^3He detectors are much more sensitive to neutrons compared with ^{235}U fission chamber, these will work in the low-neutron yield shots. Also, in *in situ* calibration described in Sec. IV, expected number of pulse counts of ^{10}B and/or ^3He detectors is much higher than that of the fission chamber. Therefore, ^{10}B and/or ^3He detectors can help pulse statistics issue of the fission chamber in *in situ* calibration.

B. Digital signal processing unit prototype

TOSHIBA has developed a DSP unit prototype to measure a neutron emission rate over a wide measurement field with fast response for radiation safety purposes. The unit is a standard 19-in. rack at 4U high. Figure 3 shows the signal processing block diagram of this unit. The unit measures analog input signals, which are generated in a fission chamber and then amplified with a preamplifier. The unit calculates a neutron counting rate from those input signals using two different methods simultaneously. One of those methods is a pulse counting method applied for a low counting rate

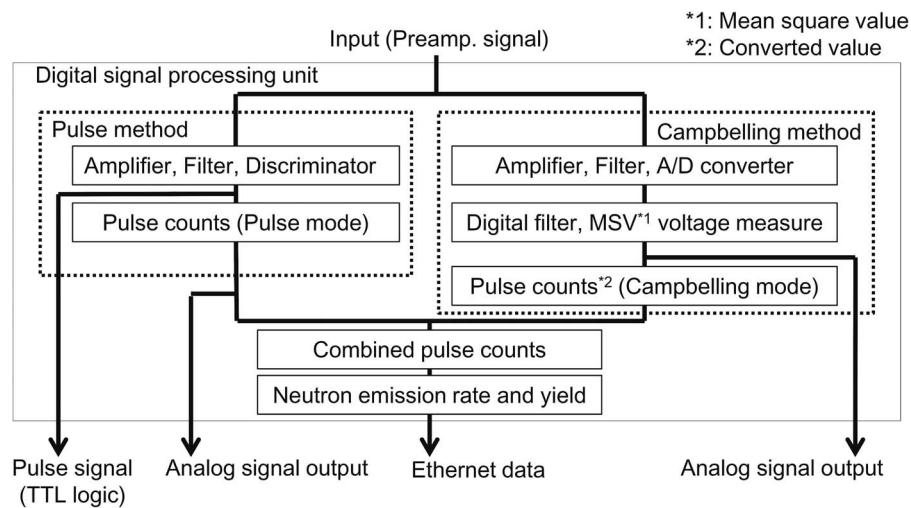

FIG. 3. Signal processing block diagram of this unit. The unit measures and processes input signals by two different methods, and calculates neutron emission rate and yield.

which is called a pulse counting mode; the other is a method to measure and process a mean square value (MSV) voltage for a high counting rate, which is called Campbelling mode. Two different results calculated, respectively, with those two methods are combined to obtain a neutron emission rate and yield over the entire region typically up to 5×10^9 counts/s. Figure 4 shows respective shapes of the signals calculated with the pulse and Campbelling modes. These signals have a sufficient overlapping region which is wide enough to make a smooth transition from one to another between those methods. The upper and lower boundary values of this region, 6×10^5 and 6×10^4 counts/s, respectively, have been obtained through a trial evaluation at KUCA as mentioned below, and these boundaries are adjustable depending upon various fission chamber types. Leading-edge digital processing technologies using field-programmable gate array, so-called FPGA, such as high sampling rate, high-speed analog-to-digital conversion, and digital signal processing are incorporated in this unit. These technologies have realized the fast response of 2 ms. Furthermore, these technologies made it possible to shorten the time constant of analog filter circuits

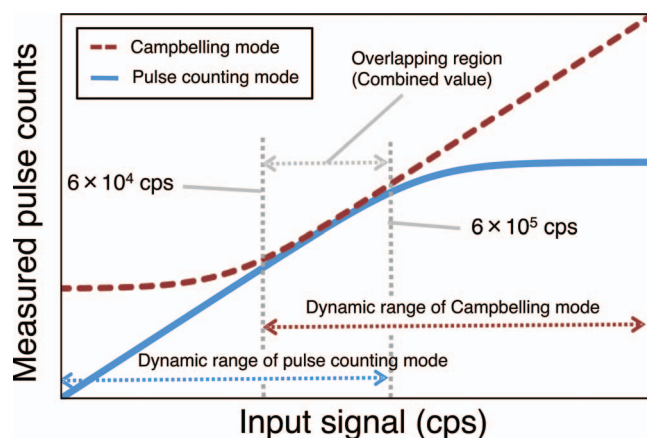

FIG. 4. Respective shapes of signals calculated by pulse counting and Campbelling modes.

and to realize better performance of a low-pass filter in the radio frequency region as compared to those obtained through conventional analog technologies. In addition, this unit has interfaces convenient for safety operation, data acquisition for plasma physics, and maintenance, including analog signal outputs, digital signal outputs, Ethernet and serial data communication, as well as numerical and text displays. For radiation safety, the unit generates an interlock signal when a neutron yield exceeds a predetermined limit.

III. OPERATION TEST AT KUCA

The prototype of DSP unit was tested in KUCA to check its usability and performance of the unit in December 2013. In particular, continuity from the pulse counting mode to the Campbelling mode was of great concern because the NFM system will work in the pulse counting mode in *in situ* calibration whereas it will be mainly operated in the Campbelling mode in actual deuterium-beam-heated LHD discharges. In this test, a ^{235}U fission chamber loaned from the KUCA facility, WL-8073 of Westinghouse Electric Co., was employed. The fission chamber was inserted into the research reactor and thermal neutron fluxes up to $\sim 10^7 \text{ cm}^{-2} \text{ s}^{-1}$ were irradiated. The Campbelling mode consists of three different schemes in gain, i.e., H-gain, M-gain, and L-gain. In the KUCA, a test of the Campbelling mode up to M-gain could be managed. Numbers of output pulses indicated by our system were proportional to the fission chamber and the uncompensated ion chamber (UIC) of the KUCA installed inside the reactor, and γ -ray monitor placed on the reactor hall wall. As an example, a result of comparison in time evolution of signal outputs between our system and the KUCA UIC is shown in Fig. 5. Good agreement can be recognized between the two in time trend. An unwanted sharp peak is seen on our signal. Judging from detailed analysis for the Campbelling mode signals, the sharp peak is not due to failure of our system, and is rather due to noise. It should be noted that this issue can be overcome by employing robust electromagnetic shield and/or noise cut filter for the power line.

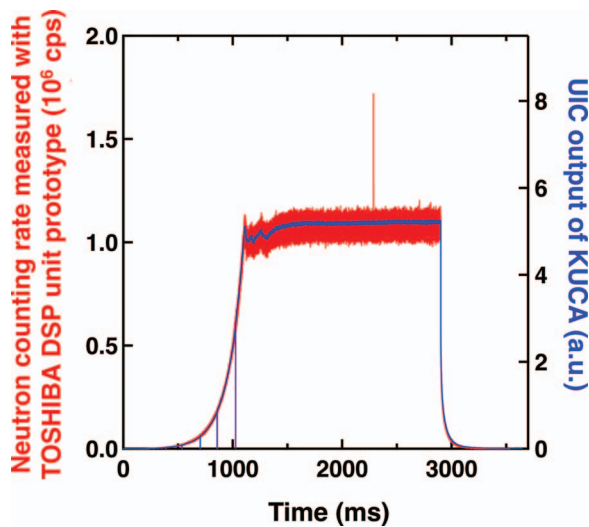

FIG. 5. Comparison of time trend of output signals between developed NFM equipped with the DSP prototype and the UIC of KUCA. Both signals are normalized in the neutron decay phase.

IV. EFFORTS TOWARD *IN SITU* CALIBRATION

It is necessary to perform *in situ* calibration of NFM to evaluate the total neutron emission rate from pulse counts measured with NFM.¹⁶ In the LHD, a ²⁵²Cf spontaneous fission neutron source of 800 MBq will be used for *in situ* calibration, emitting neutrons with the mean energy of ~ 2.1 MeV. The method consists of laying track at the major radius of 3.74 m inside the LHD vacuum vessel (Fig. 6). The track used in the LHD is a standardized article, a so-called O-gauge. To approximate the ring-shaped neutron source, we let the ²⁵²Cf source mounted on the train run on the circular track inside the LHD vacuum vessel. The train receives electric power from the track and goes around in about 30 s per turn. According



FIG. 6. Test installation of track inside the LHD vacuum vessel that will be used for *in situ* NFM calibration.

to the MCNP calculation, counting rate of ~ 1 counts/s or less is expected.¹¹ To avoid rescue circumstance of the source, the train and track system should be reliable. To date, we have developed a train that can run continuously for at least three days. Also, test installation of the track inside the vacuum vessel has been performed twice already to measure the time necessary to install, and to find points at issue for the installation.

V. SUMMARY

In summary, the LHD project will step into deuterium experiments to explore higher-performance helical plasma after some two years of preparation. The fast response, wide dynamic range NFM is essential in the LHD deuterium operation in terms of both radiation safety and plasma physics. The DSP unit developed for LHD provides the maximum counting capability up to $\sim 5 \times 10^9$ counts/s with time response of 2 ms. A satisfactory prospect was obtained toward manufacture of actual DSP unit for NFM on the LHD through carefully done design work of the system, noise tests in the LHD environment, and preliminary operation tests in the KUCA.

ACKNOWLEDGMENTS

This work was supported by the LHD project budget (ULGG801). This work was partly performed with the support and under the auspices of the NIFS Collaboration Research program (KOA029), and under the Visiting Researchers Program of Kyoto University Research Reactor Institute. M.I. also wishes to thank generous supports by the JSPS-NRF-NSFC A3 Foresight Program in the field of Plasma Physics (NSFC: No. 11261140328, NRF: No. 2012K2A2A6000443) and JSPS Grant-in-Aid for Scientific Research (B) Grant No. 26289359.

¹O. Kaneko *et al.*, *Nucl. Fusion* **53**, 104015 (2013).

²A. Iiyoshi *et al.*, *Nucl. Fusion* **39**, 1245 (1999).

³Y. Takeiri *et al.*, in *Joint 19th International Stellarator and Heliotron Workshop and 16th International Energy Agency-RFP Workshop*, Padova, 16–20 September 2013, B14.

⁴K. Nishimura *et al.*, *Plasma Fusion Res.* **3**, S1024 (2008).

⁵M. Isobe *et al.*, *Rev. Sci. Instrum.* **81**, 10D310 (2010).

⁶Y. Endo *et al.*, *IEEE Trans. Nucl. Sci.* **NS-29**, 714 (1982).

⁷H. W. Hendel *et al.*, in *Proceedings of the 4th ASTM-EURATOM Symposium on Reactor Dosimetry* (National Bureau of Standards, Washington, DC, 1982), CONF-820321/V2, p. 949.

⁸A. C. England *et al.*, *Rev. Sci. Instrum.* **57**, 1754 (1986).

⁹T. Nishitani, *J. Plasma Fusion Res.* **68**, 6 (1992) (in Japanese).

¹⁰K. Kobayashi *et al.*, *Nucl. Sci. Eng.* **71**, 143 (1979).

¹¹N. Nishio *et al.*, *Rev. Sci. Instrum.* **81**, 10D306 (2010).

¹²N. Nishio *et al.*, *Plasma Fusion Res.* **6**, 2405115 (2011).

¹³Y. Nakano *et al.*, “Study on in-situ calibration for neutron flux monitor in the helical type fusion experimental device based on Monte Carlo calculations,” *Plasma Fusion Res.* (to be published).

¹⁴Y. Nakano *et al.*, “Study on in-situ calibration for neutron flux monitor in the Large Helical Device based on Monte Carlo calculations,” *Rev. Sci. Instrum.* (these proceedings).

¹⁵T. Nishitani *et al.*, *Rev. Sci. Instrum.* **63**, 5270 (1992).

¹⁶J. D. Strachan *et al.*, *Rev. Sci. Instrum.* **61**, 3501 (1990).