

§1. Electron Bernstein Wave Heating by Long Wavelength Microwave in a Spherical Tokamak and a Helical Device

Maekawa, T., Tanaka, H., Uchida, M., Yoshinaga, T. (Kyoto Univ.),
Ikeda, R., Takeuchi, M., Shoji, T. (Nagoya Univ.),
Toi, K., Suzuki, C.

On the LATE device at Kyoto University, formation of Spherical Tokamak by ECRH without center solenoid have been conducted [1,2], while on the CHS device at NIFS, experiments for transport study based on the “non-dimensionally similar approach” have been conducted to simulate various transport processes in high temperature plasmas[3]. In both cases, the plasmas are generated and maintained by ECRH in over-dense regime via mode-converted electron Bernstein waves (EBW) from long wavelength microwaves and efficient coupling from external microwaves to EBW is crucial for experiments.

Main objective of the LATE (Low Aspect ratio Torus Experiment) device is to demonstrate formation of ST plasmas by electron cyclotron heating (ECH) alone without center solenoid and establish its physical bases. By injecting a 2.45 GHz microwave pulse for 2 seconds, a plasma current of 2 kA is spontaneously initiated by Prf=15 kW under a weak steady vertical field of $B_v=17$ Gauss, and then ramped up with slow ramp-up of Prf and slow ramp-up of B_v for the equilibrium of the plasma loop and finally reaches 8 kA at $B_v=90$ Gauss and Prf=35kW. In the case of a 5 GHz microwave pulse (130 kW, 60 ms), final plasma current reaches 12 kA at $B_v=100$ Gauss. In both cases the plasma center locates near the second or third harmonic EC resonance layer as shown in Fig.1 and the line averaged electron density significantly exceeds the plasma cutoff density, suggesting that harmonic EC heating by the mode-converted EBW supports the plasma. The mode conversion rate is estimated based on the plasma slab model [4] and compared with the 5 GHz experiments. In 5 GHz case, the wavelength is relatively short compared with the plasma size and launcher diameter. Therefore, the conditions may meet the slab model. The slab theory predicts that oblique injection with left-handed circular polarization can give 90 % mode-conversion rate, while mode-conversion rate by the right-handed circular polarization is poor. However, there has been no appreciable difference observed between two polarizations.

In CHS, over-dense plasmas were routinely produced by 2.45 GHz microwaves which were launched perpendicularly or obliquely to the toroidal field, into hydrogen, helium or neon gas [5]. In these experiments, toroidal magnetic field was scanned from 1000 G to 600 G in the magnetic configurations of $R_{ax}=97.4$ cm, 94.9cm, 101.6cm and 92.1cm, where R_{ax} denotes the magnetic axis position in the vacuum field. Radial profiles of electron temperature, electron density and plasma potential were measured with three sets of triple Langmuir probes placed on the top of the vertically elongated section, and on the inboard and outboard sides

of horizontally elongated sections. Fluctuation data of these plasma parameters were also taken by these probes. Two-dimensional electron density profile was obtained by a sheet-type Lithium beam probe developed by our group and successfully applied to LHD [6]. Radial profile of $H\alpha$ emission profile was measured by a ten-channel visible spectrometer for evaluation of neutral atom density. In order to clarify mode conversion to EBW and absorption mechanism, experiments of ECH power-step and modulation were carried out. Higher modulation frequency of 7kHz or 9kHz was adopted to directly derive a power deposition profile. For these frequencies, time delay of response signals such as electron temperature and density perturbations by the modulated ECH power is almost no radial dependence. This indicates that radial profiles of these responses will correspond to the deposition profile of mode-converted EBW power. It is inferred from these data that EBW power is dominantly absorbed in interior region beyond the upper hybrid layer in over-dense plasmas.

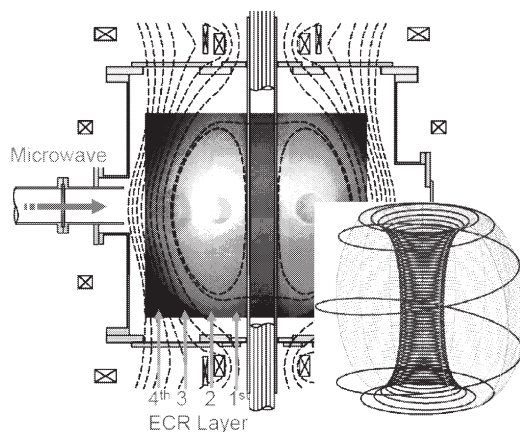

Fig. 1 The plasma encompasses the first to forth harmonic ECR layers (results from the LATE device)

References

- [1] T. Maekawa *et al.* Nuclear Fusion, **45** (2005)1439.
- [2] T. Yoshinaga *et al.*, Phys. Rev. Lett., **96**(2006)125005
- [3] K. Toi *et al.*, 29th EPS on Plasma Physics and Controlled Fusion, Montereux, 2002, paper No.P4-06.
- [4] H. Igami *et al.*, Plasma Phys. and Control. Fusion, **46** (2004) 261
- [5] R. Ikeda *et al.*, J. Plasma Fusion Res., **81** (2005) 478.
- [6] Y. Takahashi *et al.*, Plasma and Fusion Res. :Rapid Communications, **1**(2006)013-1.